



316 W. Boone Ave., Suite 450  
Spokane, WA 99201-2348  
509.323.2950 (phone)  
509.323.2979 (fax)

---

Date: November 7, 2014

Subject: EWP - Carlton Complex Fire - Bid Schedule, Plans and Specifications

To: Bob Clark  
From: Kelly Scott

Mr. Clark,

Attached are the bid schedule, plans and specifications for the Carlton Complex Fire Phase 1. Phase 1 includes sites 10, 13, 14, 18, 21 and 22. These sites were identified as a risk for potential flood damage due to the recent fires through the Emergency Watershed Program administered by NRCS.

If you have any additional questions, please let me know.

Thanks,

Kelly

## *Bid Schedule*

**BID SCHEDULE**  
**CARLTON COMPLEX FIRE EWP FLOOD PROTECTION MEASURES PROJECT**  
**OKANOGAN, COUNTY**  
**WASHINGTON**

| Item No. | Work or Material | Spec. No. | Quantity | Unit     | Unit Price | Amount   |
|----------|------------------|-----------|----------|----------|------------|----------|
| 1        | Earth Fill       | 23        | 1        | lump sum | \$ _____   | \$ _____ |
| Total    |                  |           |          |          |            | \$ _____ |

Note: Lump Sum Estimate Includes the Following Sites

|         |   |
|---------|---|
| Site 10 | 2' High Protection Berm                       |
| Site 13 | Face with Rock Riprap Existing Foundation Pad |
| Site 14 | 3' High Road Raise                            |
| Site 18 | 2' High Protection Berm and Road Raise        |
| Site 21 | 2' High Road Raise                            |
| Site 22 | 2' High Protection Berm and Road Raise        |

# *Drawings*

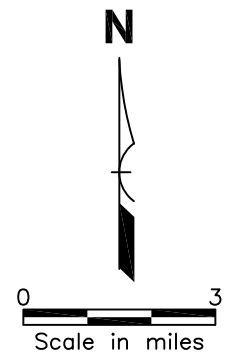

**LEGEND**

- CITY
- EWP PRIORITY SITE
- STATE ROUTE
- FEDERAL HIGHWAY

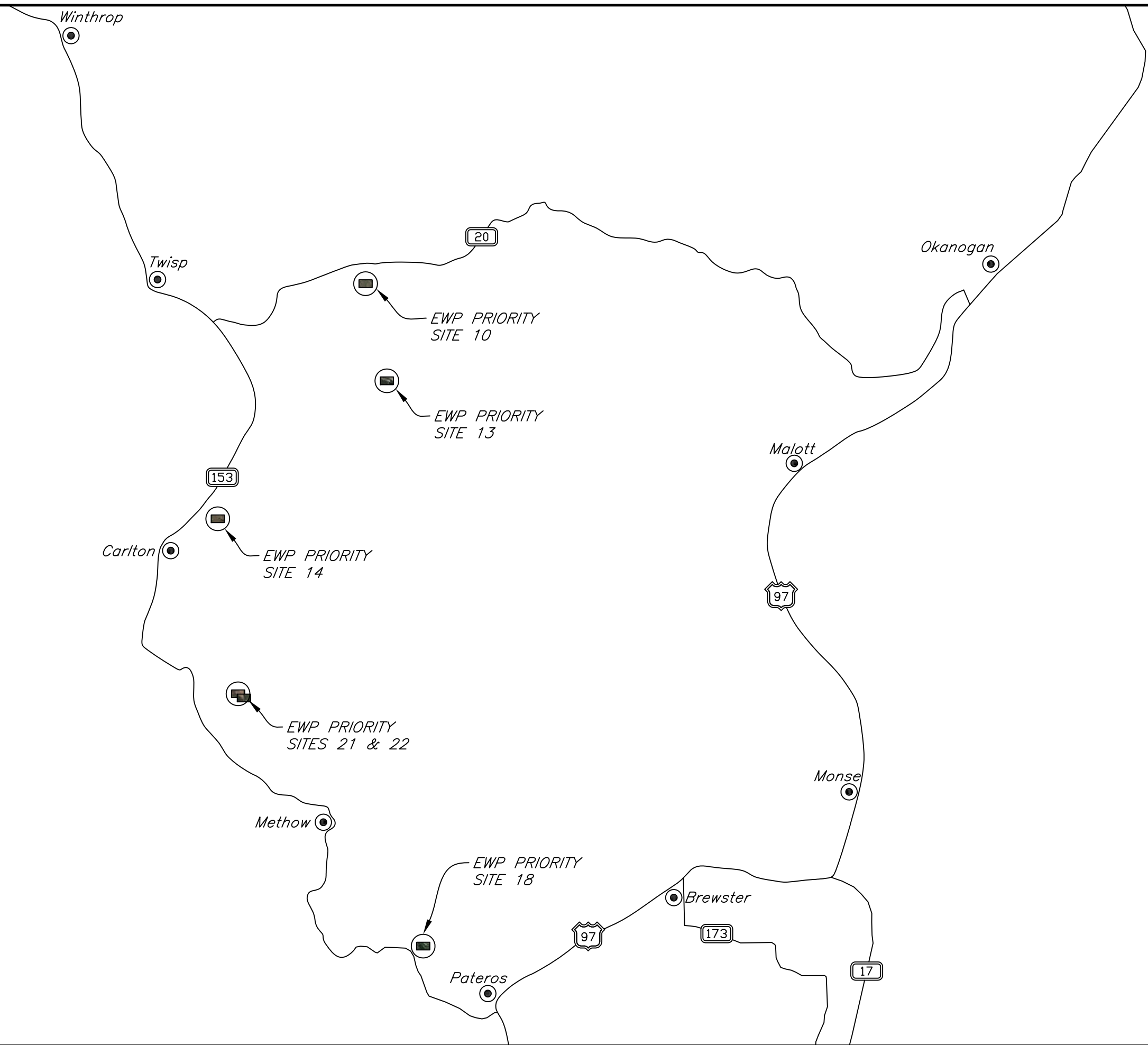

|          |       |
|----------|-------|
| Designed | _____ |
| Drawn    | _____ |
| Checked  | _____ |
| Approved | _____ |
| Date     | _____ |

**PLAN MAP**  
**PRIORITY SITES 9, 10, 13, 14, 18, 20, 21 & 22**



|              |          |
|--------------|----------|
| File Name    | _____    |
| Drawing Name | PLAN MAP |
| Sheet        | 2 of 15  |

# CARLTON COMPLEX FIRES

## EWP FLOOD PROTECTION MEASURES

UNITED STATES DEPARTMENT OF AGRICULTURE  
NATURAL RESOURCES CONSERVATION SERVICE

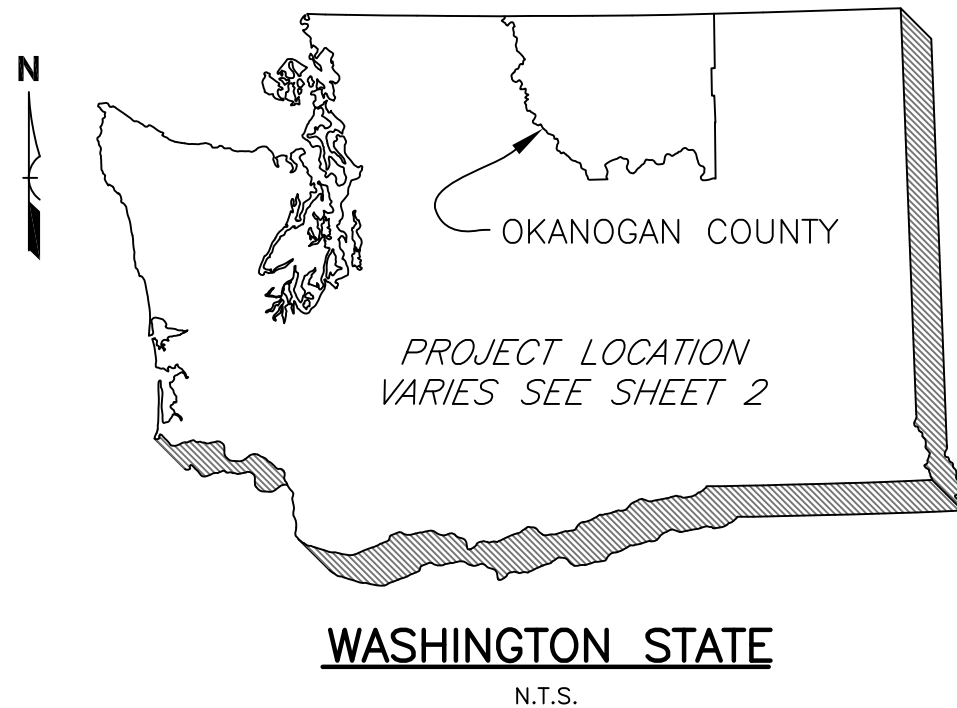

### CONDITIONS AND TERMS

The drawings, Construction and Materials Specifications, and Operation and Maintenance plan for the project are subject to revision and/or cancellation by the NRCS exactly 2 years from the date shown below in review and acceptance of the plans.

### UTILITY STATEMENT

No representation is made as to the existence or nonexistence of any utility, public and/or private, buried or overhead, except as shown on the drawings. Where utilities are shown on the drawings, the location, depth and/or height are approximate. The exact location, depth and/or height must be determined by the utility company prior to any construction in the vicinity of the utility. **Washington State Law requires the contractor to call 811, "Call Before you Dig" 2 days prior to excavation activities.**

### RESPONSIBILITY OF PERMITS

The NRCS does not assume any responsibility in the determination, application and/or securing of any necessary permits for the construction and operation of this project. All permits are the responsibility of the owner, operator and/or contractor.

### REVIEW AND ACCEPTANCE

The drawings, Construction and Material Specifications for this project have been reviewed by me and are accepted for installation. I also acknowledge that any modifications implemented prior to review and approval by the NRCS may result in NRCS disapproval of this installation. I hereby acknowledge receipt of a copy(ies) of this plan.

### INDEX OF DRAWINGS

| <u>SHEET NO.</u> | <u>TITLE</u>            |
|------------------|-------------------------|
| 1.               | COVER SHEET             |
| 2.               | PLAN VIEW               |
| 3.               | EWP PRIORITY SITE #10   |
| 4.               | EWP PRIORITY SITE #13   |
| 5.               | EWP PRIORITY SITE #14   |
| 6.               | EWP PRIORITY SITE #18   |
| 7.               | EWP PRIORITY SITE #21   |
| 8.               | EWP PRIORITY SITE #22   |
| 9.               | EWP ROAD DETAIL         |
| 10.              | EWP BERM DETAIL         |
| 11.              | EWP DRIVABLE DIP DETAIL |
| 12.              | EWP SUPER SACK DETAIL   |
| 13.              | EWP RIBS DETAIL         |
| 14.              | EWP ROCK RIPRAP DETAIL  |

### GENERAL NOTES

- The attached NRCS Construction and Material Specifications are part of this plan and shall govern the installation of this project.
- This project shall be constructed to the lines and grades shown in the drawings and detailed in the Construction Specifications.
- The project will be operated and maintained as described in the Operation and Maintenance Plan prepared for this project.

COOPERATOR/OWNER \_\_\_\_\_

DATE \_\_\_\_\_

Date \_\_\_\_\_  
Designed \_\_\_\_\_  
Drawn \_\_\_\_\_  
Checked \_\_\_\_\_  
Approved \_\_\_\_\_

COVER SHEET



File Name \_\_\_\_\_  
Drawing Name \_\_\_\_\_  
COVER SHEET  
Sheet 1 of 15

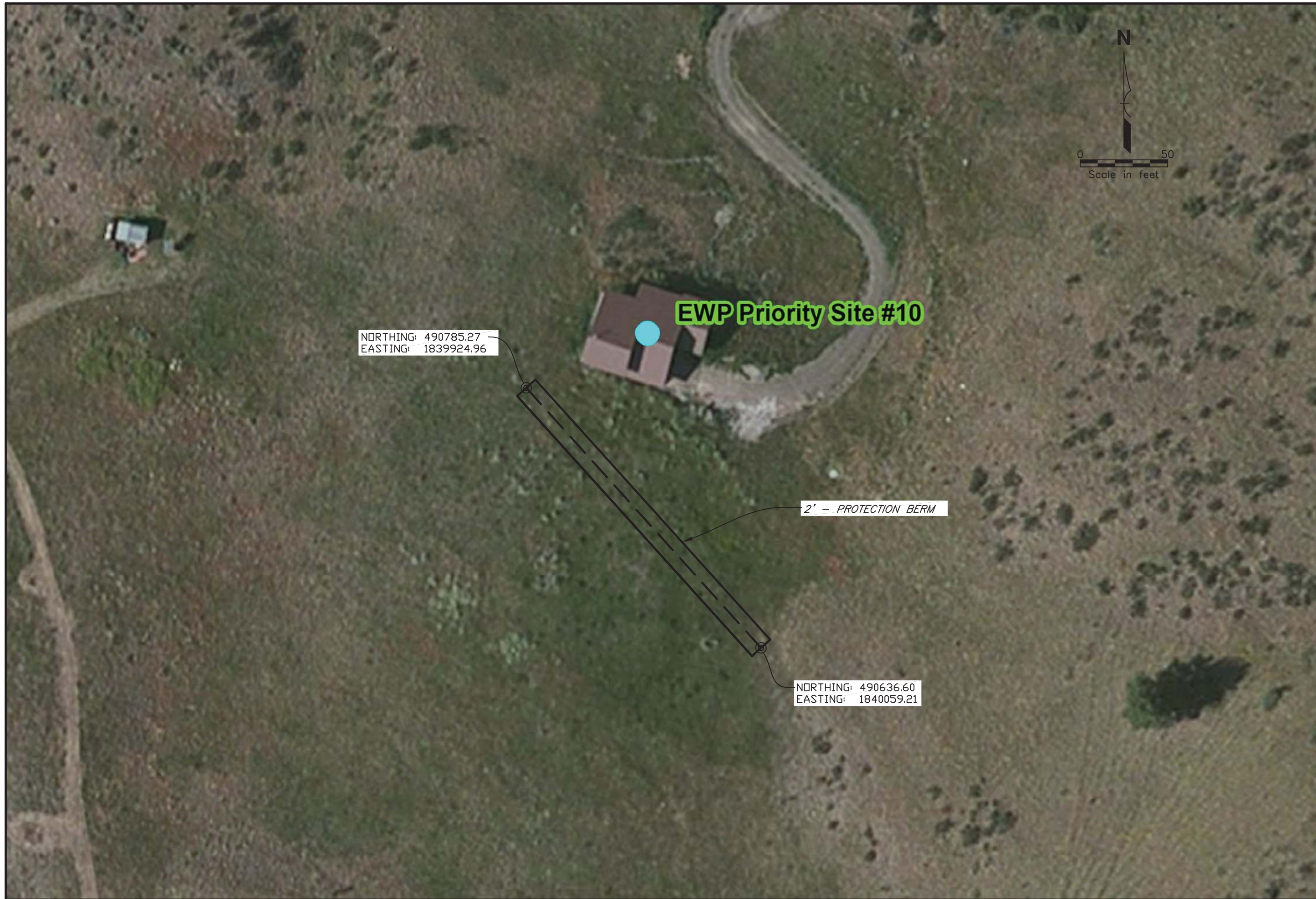

**EWP Priority Site #10**

NORTHING: 490785.27  
EASTING: 1839924.96

2' - PROTECTION BERM

NORTHING: 490636.60  
EASTING: 1840059.21



**EWP PRIORITY SITE #10**



File Name  
Drawing Name  
*SITE #10*  
Sheet 4 of 15

|          |       |      |       |
|----------|-------|------|-------|
| Designed | _____ | Date | _____ |
| Drawn    | _____ |      | _____ |
| Checked  | _____ |      | _____ |
| Approved | _____ |      | _____ |

# EWP BERM DETAIL

NRCS Practice Standard 356 Dike

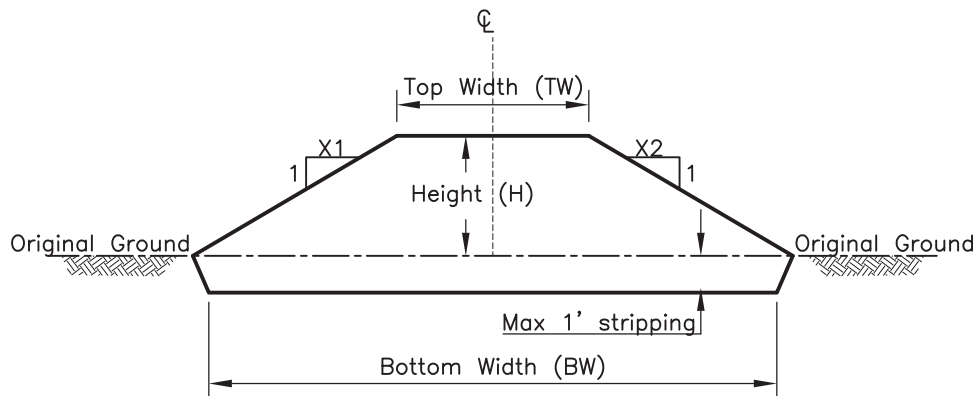
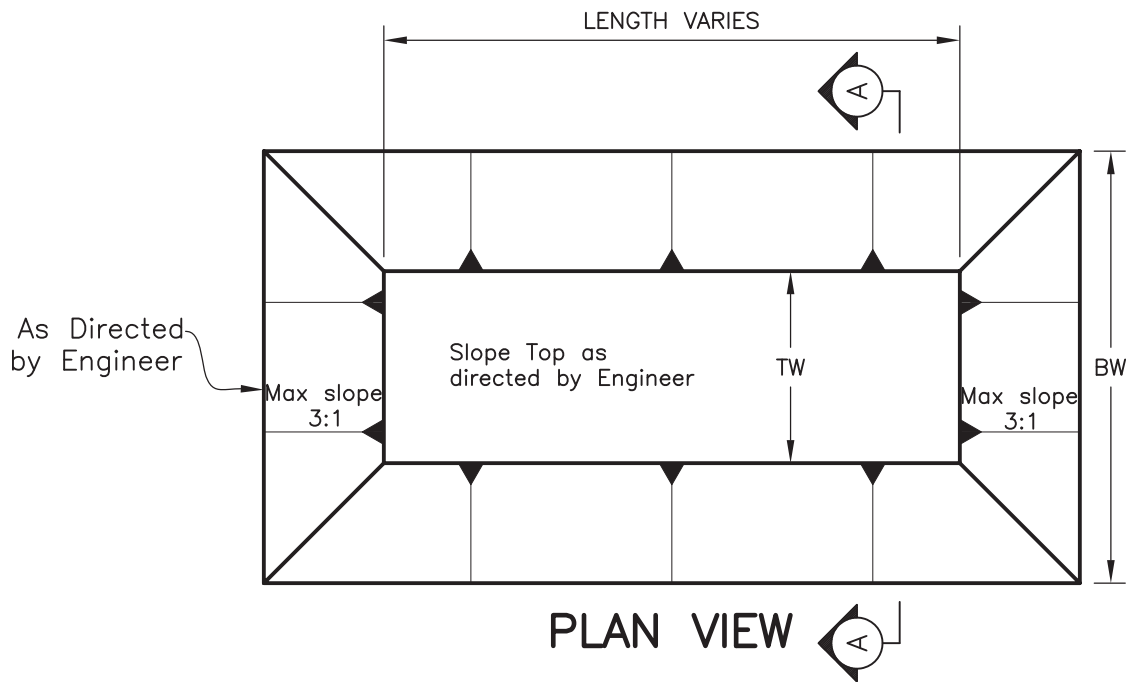

DIMENSIONS

TW = 8 (ft)

BW = 14 (ft)

H = 2 (ft)

X1 Maximum Slope = 1.5 : 1 (H:V)

X2 Maximum Slope = 1.5 : 1 (H:V)

NOTES:

This standard drawing required supporting technical documentation prior to use and must be adapted to the specific site.

Drawing not to scale

Carlton Complex Fire EWP Site 10

JOB CLASS

Date

CAD FILE NO.

Designed \_\_\_\_\_

SHEET OF

Drawn \_\_\_\_\_

Checked \_\_\_\_\_

Approved \_\_\_\_\_



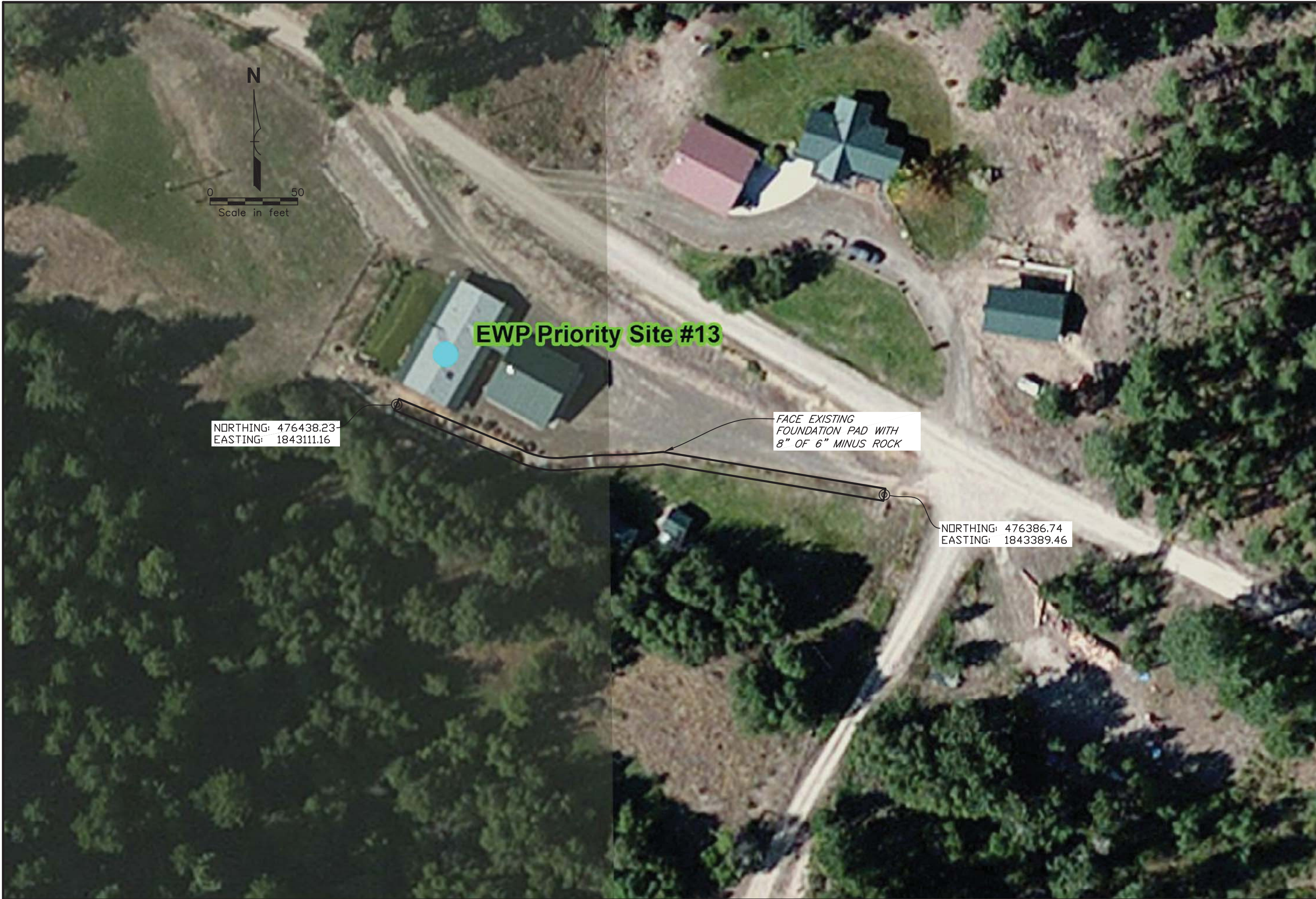

NORTHING: 476438.23  
EASTING: 1843111.16

**EWP Priority Site #13**

FACE EXISTING  
FOUNDATION PAD WITH  
8" OF 6" MINUS ROCK

NORTHING: 476386.74  
EASTING: 1843389.46

|          |       |      |       |
|----------|-------|------|-------|
| Designed | _____ | Date | _____ |
| Drawn    | _____ |      | _____ |
| Checked  | _____ |      | _____ |
| Approved | _____ |      | _____ |

**EWP PRIORITY SITE #13**



|              |          |
|--------------|----------|
| File Name    | _____    |
| Drawing Name | SITE #13 |
| Sheet        | 5 of 15  |

# EWP ROCK RIPRAP DETAIL

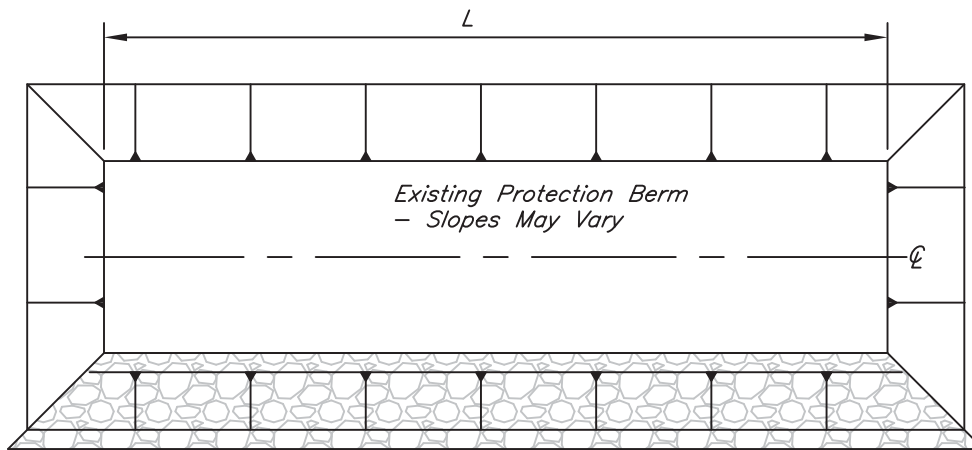

PLAN VIEW

Proposed 10" Minus Loose Rock Riprap

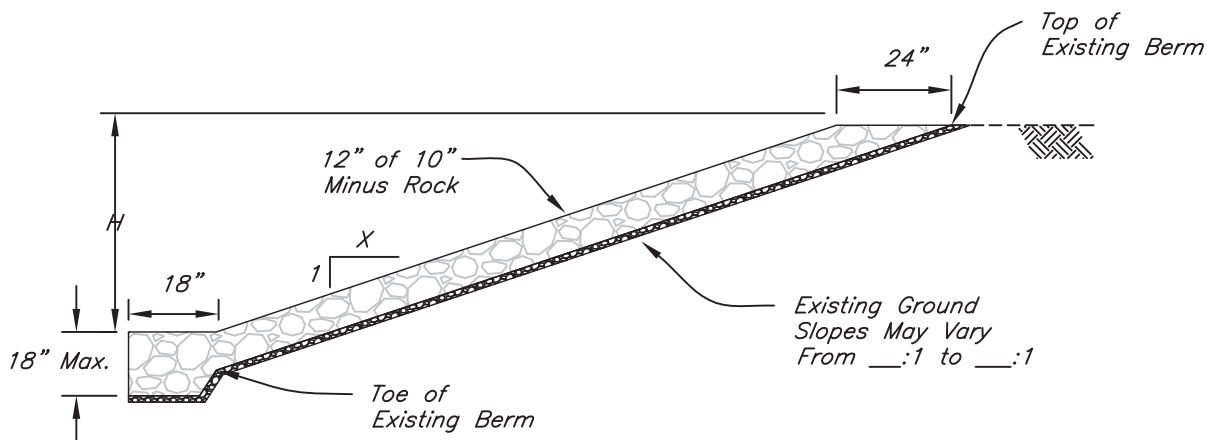

SECTION VIEW

DIMENSIONS

(L) Length = 200 (ft)

(H) Height = 8 (ft)

Side Slope (X) = 1.5:1

NOTES:

This standard drawing requires supporting technical documentation prior to use and must be adapted to the specific site.

Drawing Not To Scale

Carlton Complex Fire EWP Site 13  
Surface Rip Rap

JOB CLASS

Date

CAD FILE NO.

Designed \_\_\_\_\_

SHEET OF

Drawn \_\_\_\_\_

Checked \_\_\_\_\_

Approved \_\_\_\_\_



NORTHING: 393138.58  
EASTING: 1848426.45

NORTHING: 393012.70  
EASTING: 1848402.14

NORTHING: 393031.42  
EASTING: 1848914.67

NORTHING: 393014.01  
EASTING: 1848979.81

NORTHING: 393036.99  
EASTING: 1849043.60

NORTHING: 392823.15  
EASTING: 1848544.59

NORTHING: 392794.92  
EASTING: 1848736.62



**EWP Priority Site #18**

2' - ROAD RAISE AND  
2' - PROTECTION BERM

TRANSITION  
WHERE VARYING TOP  
WIDTHS EXIST BLEND  
OVER 10'

2' - ROAD RAISE

EWP PRIORITY SITE #18



|          |       |      |       |
|----------|-------|------|-------|
| Designed | _____ | Date | _____ |
| Drawn    | _____ |      | _____ |
| Checked  | _____ |      | _____ |
| Approved | _____ |      | _____ |

File Name

Drawing Name

SITE #18

Sheet 7 of 15

# EWP ROAD DETAIL

## NRCS Practice Standard 560 Access Road

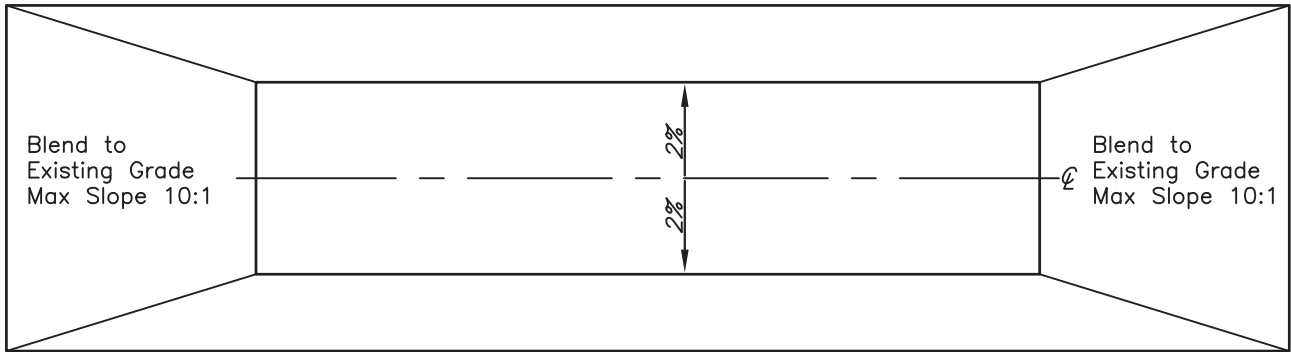

PLAN VIEW

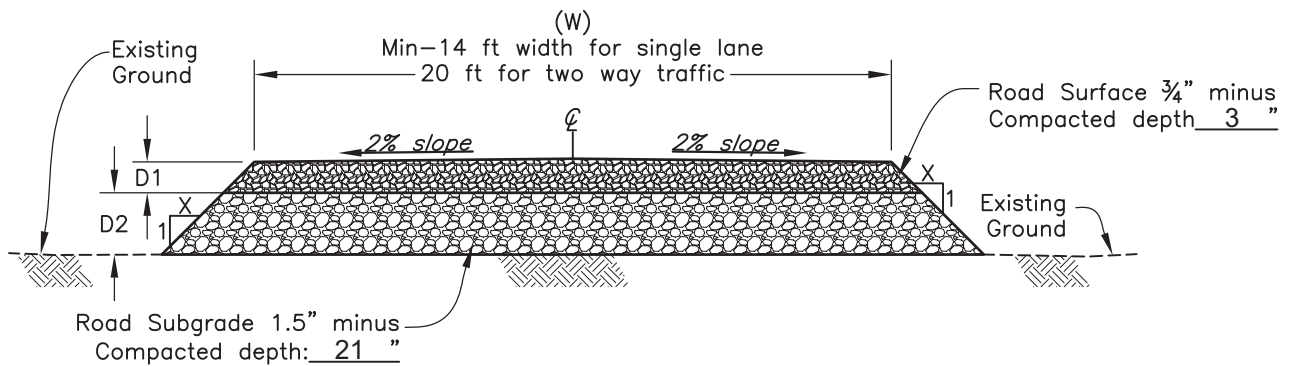

CROSS SECTION

DIMENSIONS

Road Length = 200 (ft)

(W) Width = 14 (ft)

(D1) Depth = 3 (in)  
of Compacted Roadfill

(D2) Depth = 21 (in)  
of Compacted Roadfill

Side Slope (X) = 1.5 :1

NOTES:

This standard drawing requires supporting technical documentation prior to use and must be adapted to the specific site.

Grades should not exceed 10% except for short lengths.

All cuts and fill shall have side slopes designed to be stable for the site conditions.

Surface of road depends on use.

Recommended intersection with public roads to be at an angle of 90 degrees.

Drawing Not To Scale

Carlton Complex Fire EWP Site #18  
Lower House Road Raise

JOB CLASS

Date

CAD FILE NO.

Designed \_\_\_\_\_

SHEET OF

Drawn \_\_\_\_\_

Checked \_\_\_\_\_

Approved \_\_\_\_\_

# EWP BERM DETAIL

NRCS Practice Standard 356 Dike

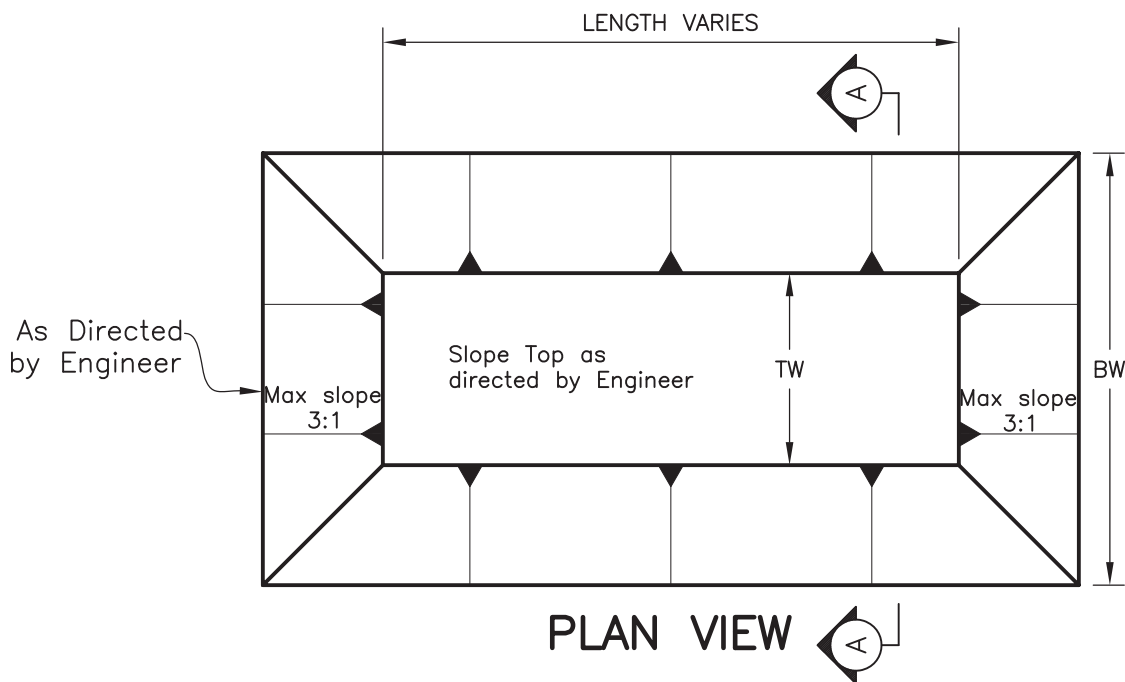

Dike to protect upper house = 225 feet long

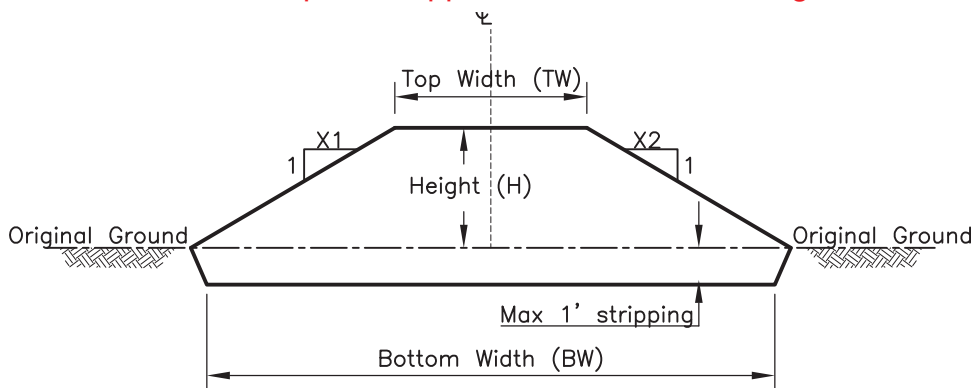

DIMENSIONS

TW = 10 (ft)

BW = 16 (ft)

H = 2 (ft)

X1 Maximum Slope = 1.5 : 1 (H:V)

X2 Maximum Slope = 1.5 : 1 (H:V)

NOTES:

This standard drawing required supporting technical documentation prior to use and must be adapted to the specific site.

Drawing not to scale

Carlton Complex Fire EWP Site 18

JOB CLASS

Date

CAD FILE NO.

Designed \_\_\_\_\_

SHEET OF

Drawn \_\_\_\_\_

Checked \_\_\_\_\_

Approved \_\_\_\_\_

# EWP ROAD DETAIL

## NRCS Practice Standard 560 Access Road

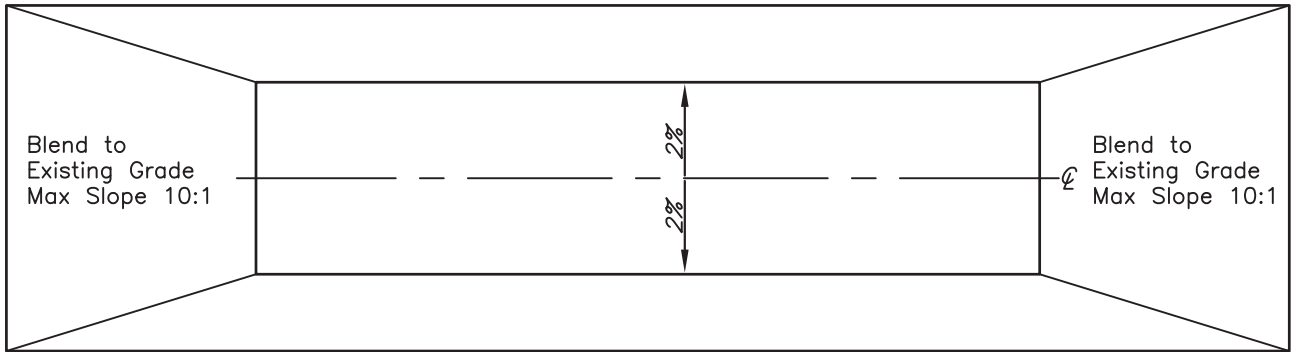

PLAN VIEW

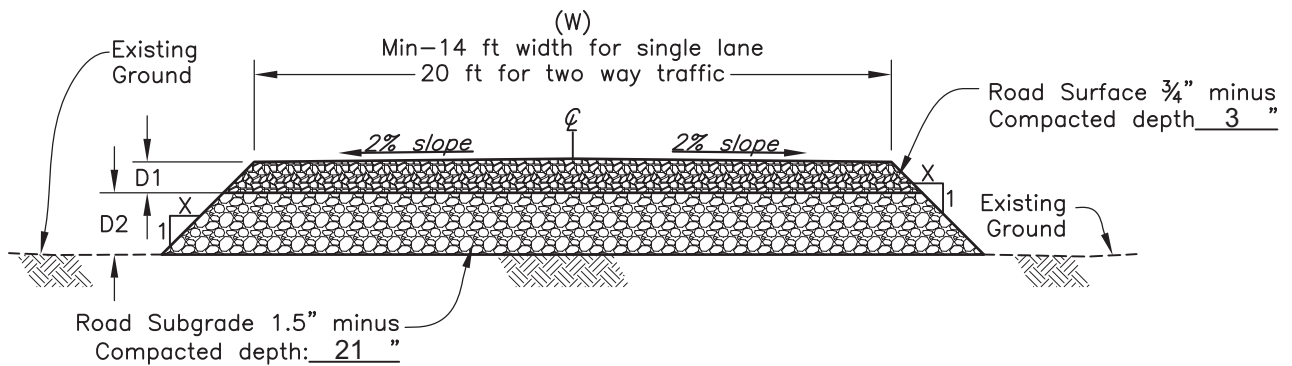

CROSS SECTION

DIMENSIONS

Road Length = 360 (ft)

(W) Width = 14 (ft)

(D1) Depth = 3 (in)  
of Compacted Roadfill

(D2) Depth = 21 (in)  
of Compacted Roadfill

Side Slope (X) = 1.5 :1

NOTES:

This standard drawing requires supporting technical documentation prior to use and must be adapted to the specific site.

Grades should not exceed 10% except for short lengths.

All cuts and fill shall have side slopes designed to be stable for the site conditions.

Surface of road depends on use.

Recommended intersection with public roads to be at an angle of 90 degrees.

Drawing Not To Scale

Carlton Complex Fire EWP Site #18  
Upper House Road Raise

JOB CLASS

Date

CAD FILE NO.

Designed \_\_\_\_\_

SHEET OF

Drawn \_\_\_\_\_

Checked \_\_\_\_\_

U.S.D.A. NATURAL RESOURCES CONSERVATION SERVICE

Approved \_\_\_\_\_



NORTHING: 456119.50  
EASTING: 1817554.92

**EWP Priority Site #14**

3' - ROAD RAISE

NORTHING: 455927.21  
EASTING: 1817556.26



|          |       |      |       |
|----------|-------|------|-------|
| Designed | _____ | Date | _____ |
| Drawn    | _____ |      | _____ |
| Checked  | _____ |      | _____ |
| Approved | _____ |      | _____ |

**EWP PRIORITY SITE #14**



|              |          |
|--------------|----------|
| File Name    | _____    |
| Drawing Name | SITE #14 |
| Sheet        | 6 of 15  |

NRCS Practice Standard 560 Access Road

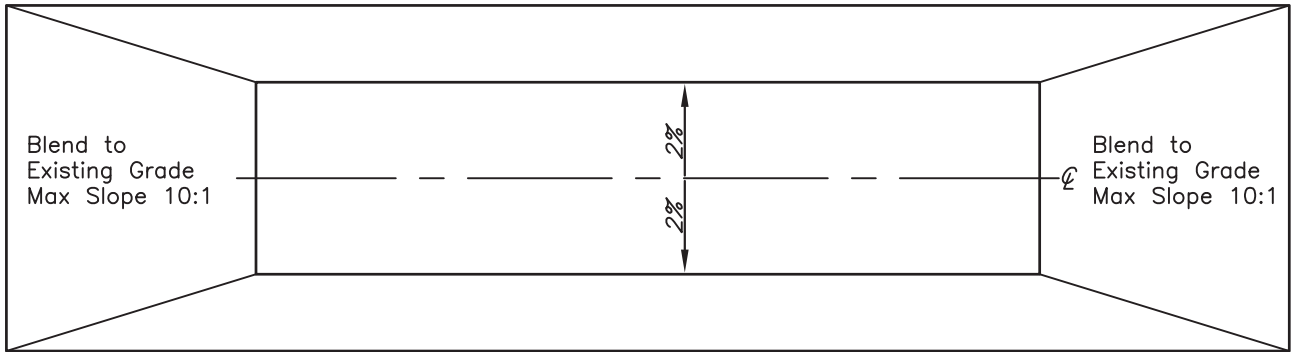

PLAN VIEW

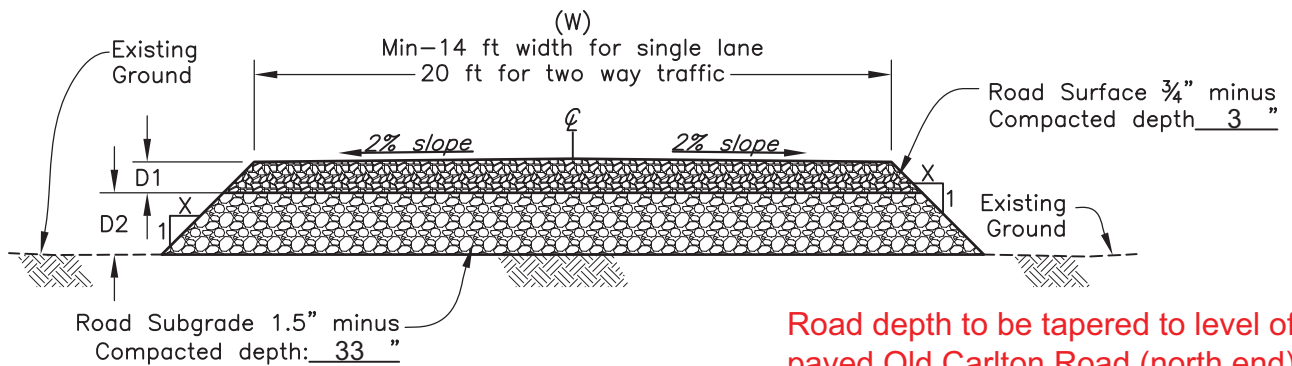

CROSS SECTION

Road depth to be tapered to level of paved Old Carlton Road (north end) and to level of ground rise approximately 50-60 feet South of fence corner. Road length = 200 ft. plus South end taper.

DIMENSIONS

Road Length = 200 (ft)

(W) Width = 14 (ft)

(D1) Depth = 3 (in)  
of Compacted Roadfill

(D2) Depth = 33 (in)  
of Compacted Roadfill

Side Slope (X) = 1.5 :1

NOTES:

This standard drawing requires supporting technical documentation prior to use and must be adapted to the specific site.

Grades should not exceed 10% except for short lengths.

All cuts and fill shall have side slopes designed to be stable for the site conditions.

Surface of road depends on use.

Recommended intersection with public roads to be at an angle of 90 degrees.

Drawing Not To Scale

Carlton Complex Fire EWP Site 21

JOB CLASS

Date

CAD FILE NO.

Designed \_\_\_\_\_

SHEET OF

Drawn \_\_\_\_\_

Checked \_\_\_\_\_

Approved \_\_\_\_\_



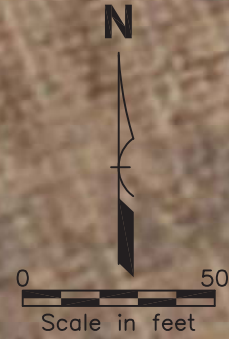
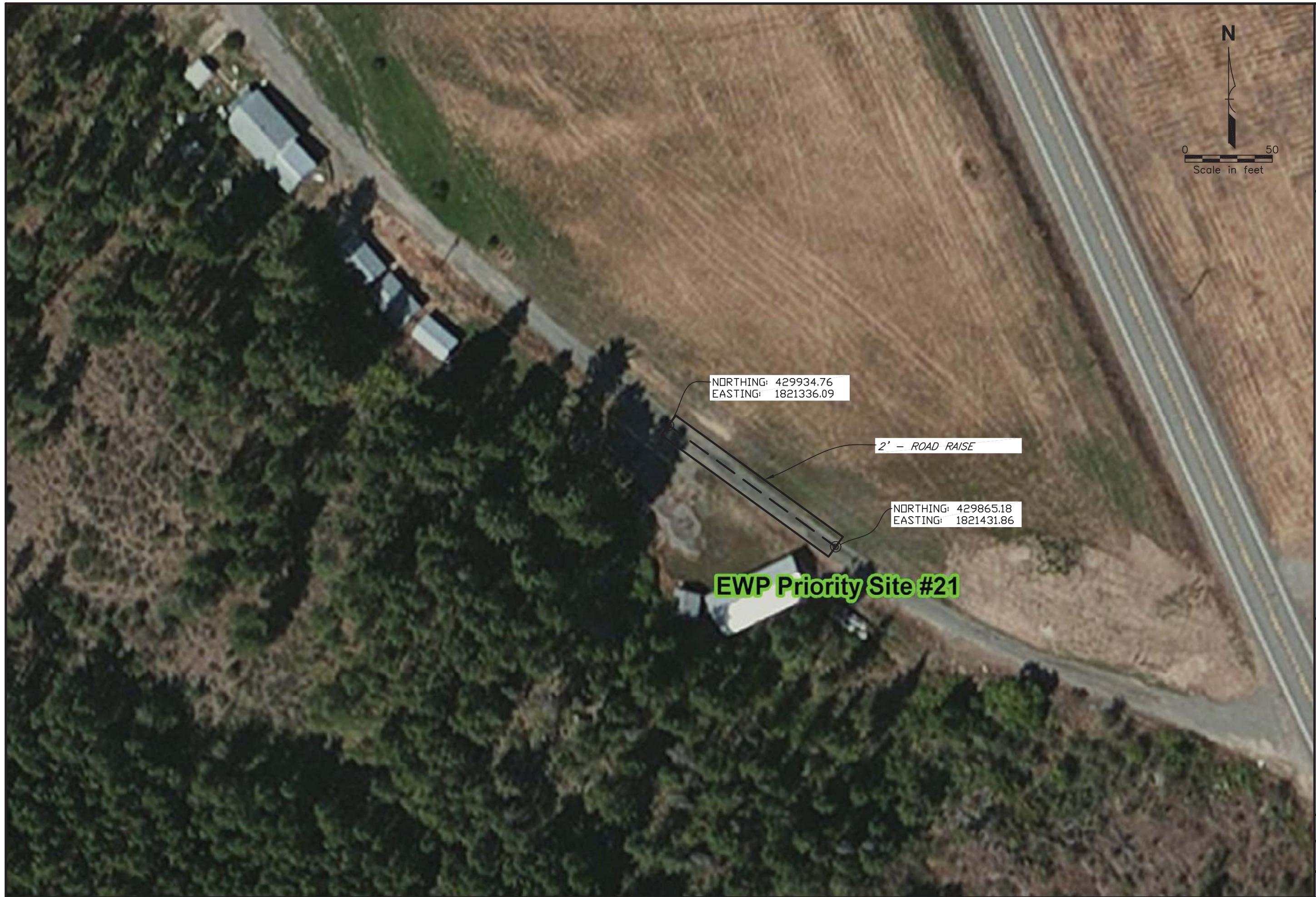

NORTHING: 429934.76  
EASTING: 1821336.09

2' - ROAD RAISE

NORTHING: 429865.18  
EASTING: 1821431.86

**EWP Priority Site #21**

**EWP PRIORITY SITE #21**



|          |       |      |       |
|----------|-------|------|-------|
| Designed | _____ | Date | _____ |
| Drawn    | _____ |      | _____ |
| Checked  | _____ |      | _____ |
| Approved | _____ |      | _____ |

# EWP ROAD DETAIL

## NRCS Practice Standard 560 Access Road

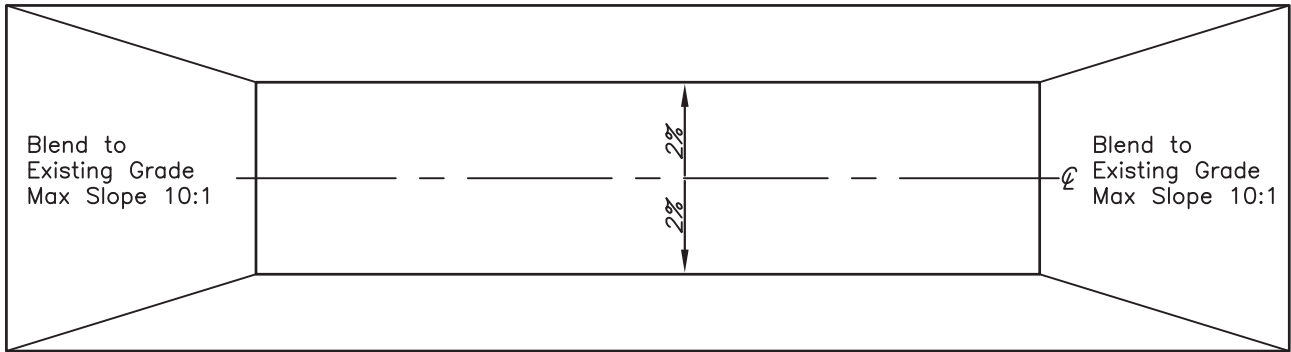

PLAN VIEW

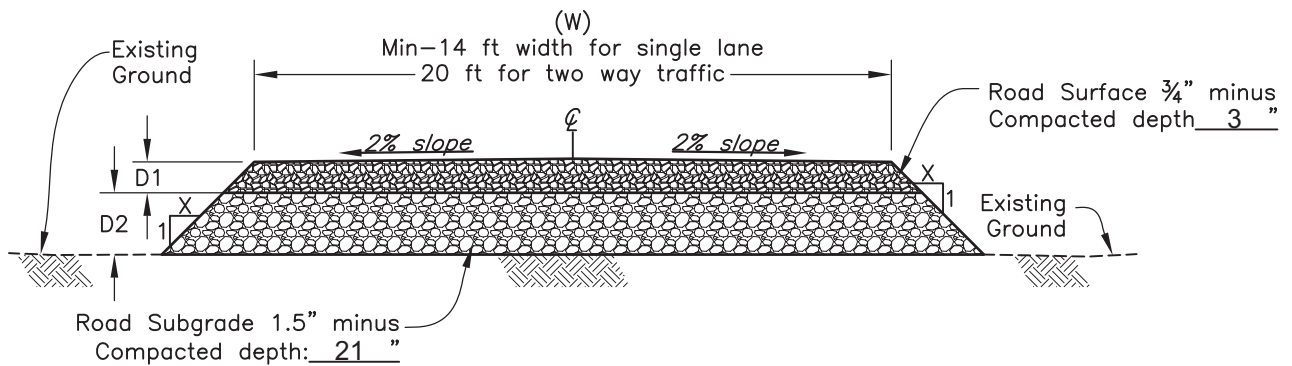

CROSS SECTION

Road build-up shall be tapered to match existing road.

DIMENSIONS

Road Length = 200 (ft)

(W) Width = 14 (ft)

(D1) Depth = 3 (in)  
of Compacted Roadfill

(D2) Depth = 21 (in)  
of Compacted Roadfill

Side Slope (X) = 1.5 :1

NOTES:

This standard drawing requires supporting technical documentation prior to use and must be adapted to the specific site.

Grades should not exceed 10% except for short lengths.

All cuts and fill shall have side slopes designed to be stable for the site conditions.

Surface of road depends on use.

Recommended intersection with public roads to be at an angle of 90 degrees.

Drawing Not To Scale

Carlton Complex Fire EWP Site 21

JOB CLASS

Date

CAD FILE NO.

Designed \_\_\_\_\_

SHEET OF

Drawn \_\_\_\_\_

Checked \_\_\_\_\_

Approved \_\_\_\_\_



|          |       |      |       |
|----------|-------|------|-------|
| Designed | _____ | Date | _____ |
| Drawn    | _____ |      | _____ |
| Checked  | _____ |      | _____ |
| Approved | _____ |      | _____ |

**EWP PRIORITY SITE #22**



|              |          |
|--------------|----------|
| File Name    | _____    |
| Drawing Name | SITE #22 |
| Sheet        | 9 of 15  |

# EWP ROAD DETAIL

## NRCS Practice Standard 560 Access Road

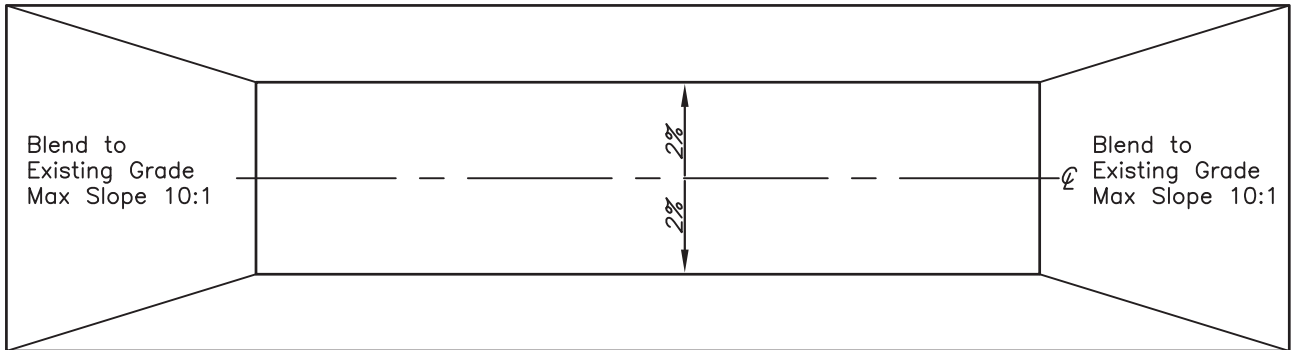

PLAN VIEW

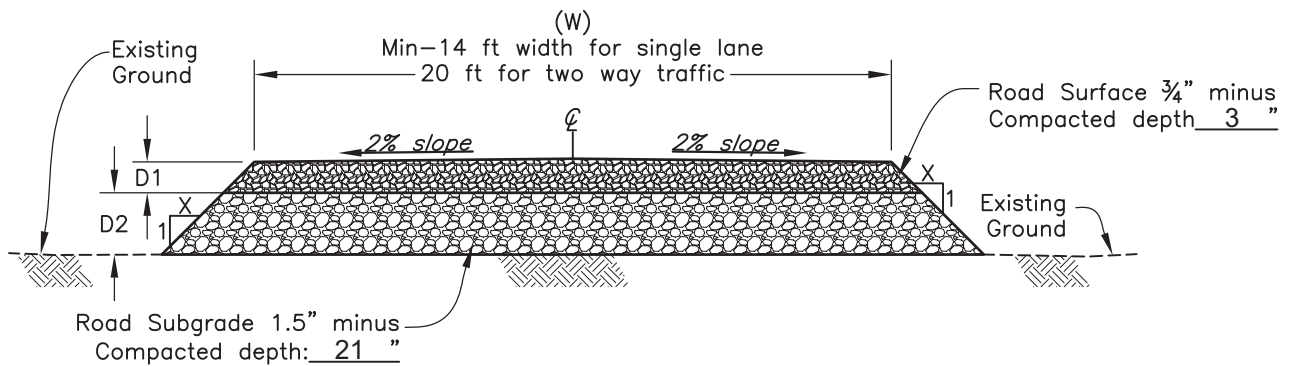

CROSS SECTION

DIMENSIONS

Road Length = 300 (ft)

(W) Width = 14 (ft)

(D1) Depth = 3 (in)  
of Compacted Roadfill

(D2) Depth = 21 (in)  
of Compacted Roadfill

Side Slope (X) = 1.5 :1

NOTES:

This standard drawing requires supporting technical documentation prior to use and must be adapted to the specific site.

Grades should not exceed 10% except for short lengths.

All cuts and fill shall have side slopes designed to be stable for the site conditions.

Surface of road depends on use.

Recommended intersection with public roads to be at an angle of 90 degrees.

Drawing Not To Scale

Carlton Complex Fire EWP Site # 22  
Road Build-up

JOB CLASS

Date

CAD FILE NO.

Designed \_\_\_\_\_

SHEET OF

Drawn \_\_\_\_\_

Checked \_\_\_\_\_

U.S.D.A. NATURAL RESOURCES CONSERVATION SERVICE

Approved \_\_\_\_\_

# EWP BERM DETAIL

NRCS Practice Standard 356 Dike

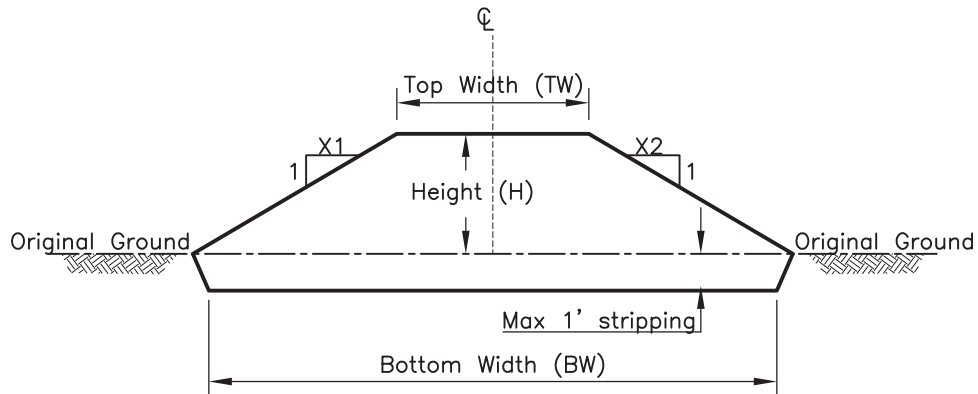
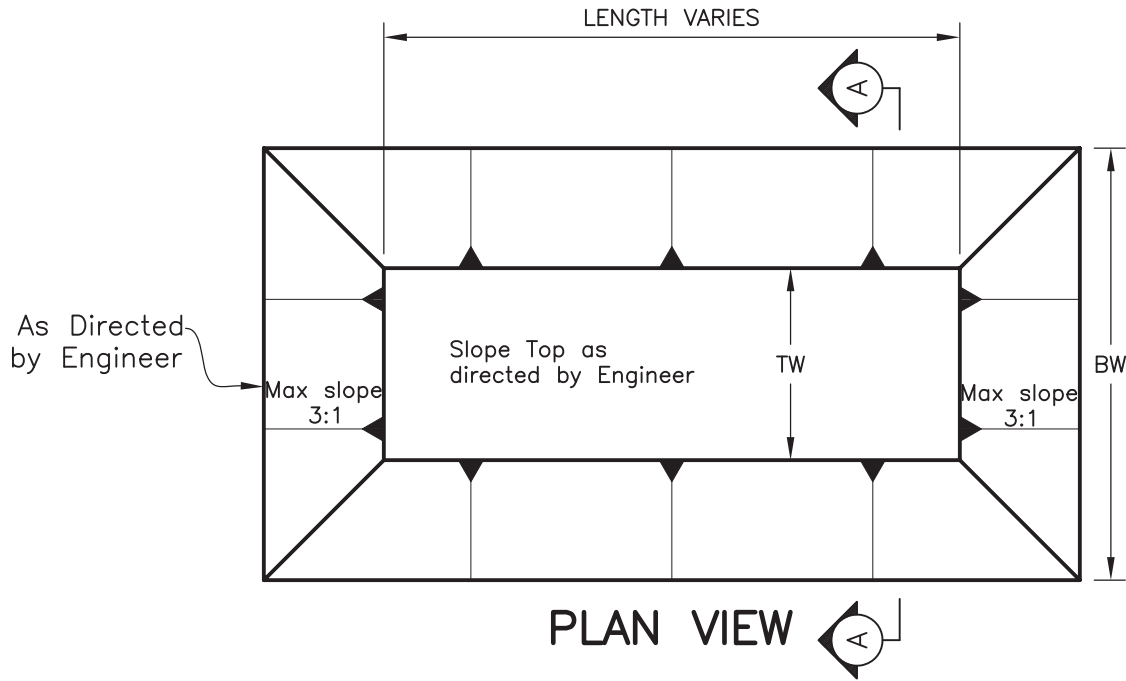

NOTES:

Berm Length = 150 (ft)

This standard drawing required supporting technical documentation prior to use and must be adapted to the specific site.

DIMENSIONS

TW = 10 (ft)

BW = 16 (ft)

H = 2 (ft)

X1 Maximum Slope = 1.5 : 1 (H:V)

X2 Maximum Slope = 1.5 : 1 (H:V)

Drawing not to scale

Carlton Complex Fire EWP Site # 22  
Berm

JOB CLASS

Date

CAD FILE NO.

Designed \_\_\_\_\_

SHEET OF

Drawn \_\_\_\_\_

Checked \_\_\_\_\_

Approved \_\_\_\_\_

## *Specifications*

*UNITED STATES DEPARTMENT OF AGRICULTURE  
NATURAL RESOURCES CONSERVATION SERVICE*

**SPECIFICATIONS FOR  
CARLTON COMPLEX FIRE EWP FLOOD PROTECTION MEASURES  
OKANOGAN COUNTY, WASHINGTON**

**TABLE OF CONTENTS**

| <b><u>CONSTRUCTION SPECIFICATION</u></b> | <b><u>NO. OF PAGES</u></b> |
|--|----------------------------|
| 2. CLEARING AND GRUBBING                 | 3                          |
| 3. STRUCTURE REMOVAL                     | 3                          |
| 5. POLLUTION CONTROL                     | 3                          |
| 7. CONSTRUCTION SURVEYS                  | 4                          |
| 8. MOBILIZATION AND DEMOBILIZATION       | 2                          |
| 10. WATER FOR CONSTRUCTION               | 3                          |
| 11. REMOVAL OF WATER                     | 3                          |
| 21. EXCAVATION                           | 5                          |
| 23. EARTHFILL                            | 7                          |
| 24. DRAINFILL                            | 5                          |
| 61. ROCK RIPRAP                          | 5                          |
| 94. CONTRACTOR QUALITY CONTROL           | 4                          |
| <br>                                     |                            |
| <b><u>MATERIAL SPECIFICATION</u></b>     | <b><u>NO. OF PAGES</u></b> |
| 523. ROCK FOR RIPRAP                     | 3                          |

# Construction Specification 2—Clearing and Grubbing

## 1. Scope

The work consists of clearing and grubbing and disposal of trees, snags, logs, brush, stumps, shrubs, and rubbish from the designated areas.

## 2. Protection of existing vegetation

Trees and other vegetation designated to remain undisturbed shall be protected from damage throughout the duration of the construction period. Any damages resulting from the contractor's operations or neglect shall be repaired by the contractor.

Earthfill, stockpiling of materials, vehicular parking, and excessive foot or vehicular traffic shall not be allowed within the drip line of vegetation designated to remain in place. Vegetation damaged by any of these or similar actions shall be replaced with viable vegetation of the same species, similar condition, and like size unless otherwise approved by the contracting officer.

Any cuts, skins, scrapes, or bruises to the bark of the vegetation shall be carefully trimmed and local nursery accepted procedures used to seal damaged bark.

Any limbs or branches 0.5 inch or larger in diameter that are broken, severed, or otherwise seriously damaged during construction shall be cut off at the base of the damaged limb or branch flush with the adjacent limb or tree trunk. All roots 1-inch or larger in diameter that are cut, broken, or otherwise severed during construction operations shall have the end smoothly cut perpendicular to the root. Roots exposed during excavation or other operations shall be covered with moist earth or backfilled as soon as possible to prevent the roots from drying out.

## 3. Marking

The limits of the area(s) to be cleared and grubbed will be marked by stakes, flags, tree markings, or other suitable methods. Trees to be left standing and uninjured will be designated by special markings placed on the trunk about 6 feet above the ground surface.

## 4. Clearing and grubbing

All trees not marked for preservation and all snags, logs, brush, stumps, shrubs, rubbish, and similar materials shall be cleared from within the limits of the designated areas. Unless otherwise specified, all stumps, roots, and root clusters that have a diameter of 1 inch or larger shall be grubbed out to a depth of at least 2 feet below subgrade for concrete structures and 1 foot below the ground surface at embankment sites and other designated areas.

## 5. Disposal

All materials cleared and grubbed from the designated areas shall be disposed of at locations shown on the drawings or in a manner specified in section 7. The contractor is responsible for complying with all local rules and regulations and the payment of any and all fees that may result from disposal at locations away from the project site.

## 6. Measurement and payment

**Method 1**—For items of work for which specific units prices are established in the contract, the cleared and grubbed area is measured to the nearest 0.1 acre. Payment for clearing and grubbing is made for the total area within the designated limits at the contract unit price. Such payment will constitute full compensation for all labor, equipment, tools, and all other items necessary and incidental to the completion of the work.



**Method 2**—For items of work for which specific unit prices are established in the contract, the length of the cleared and grubbed area is measured to the nearest full station (100 feet) along the line designated on the drawing or identified in the specifications. Payment for clearing and grubbing is made for the total length within the designated limits at the contract unit price. Such payment will constitute full compensation for all labor, equipment, tools, and all other items necessary and incidental to the completion of the work.

**Method 3**—For items of work for which specific unit prices are established in the contract, each tree, stump, and snag having a diameter of 4 inches or larger and each log having a diameter of 4 inches or larger and a length of 10 feet are measured before removal. The size of each tree and snag is determined by measuring its trunk at breast height above the natural ground surface. The size of each log is determined by measuring the butt and by measuring its length from butt to tip. The size of each stump is measured at the top. Diameter is determined by dividing the measured circumference by 3.14.

Payment for clearing and grubbing of each tree, stump, and snag having a diameter of 4 inches or larger and each log having a diameter of 4 inches or larger and a length of 10 feet or larger is made at the contract unit price for its size designation as determined by the following schedule:

| Measured diameter<br>(in) | Size designation<br>(in) |
|---------------------------|--------------------------|
| 4 to 8                    | 6                        |
| 8 to 12                   | 10                       |
| 12 to 24                  | 18                       |
| 24 to 36                  | 30                       |
| 36 to 60                  | 48                       |
| Over 60                   | 60                       |

The sum of such payments shall constitute full compensation for clearing and grubbing (including the clearing and grubbing of smaller trees, stumps, snags, logs, brush, shrubs, and roots), applicable permits and associated fees, and rubbish removal. Such payment shall constitute full compensation for all labor, equipment, tools, and all other items necessary and incidental to the completion of the work.

**Method 4**—For items of work for which specific lump sum prices are established in the contract, payment for clearing and grubbing is made at the contract lump sum price. Such payment shall constitute full compensation for all labor, equipment, tools, and all other items necessary and incidental to the completion of the work.

**All Methods**—The following provisions apply to all methods of measurement and payment. Compensation for any item of work described in the contract, but not listed in the bid schedule will be included in the payment for the item of work to which it is made subsidiary. Such items and the items to which they are made subsidiary are identified in section 7.

## 7. Items of work and construction details

## 7. Items of work and construction details

Items of work to be performed in conformance with this specification and the construction details are:

### a. Subsidiary Item, Stripping

- (1) This item shall consist of the removal of trees, logs, brush and other debris necessary for construction of the project as shown on the drawings. The Contract Officers Representative shall approve all stripped foundations prior to placement of earthfill or structures. The stripped surfaces shall be reasonably smooth and free of unconsolidated or loose soil.
- (2) In Section 3, Marking, the limits will not be marked. The project location will be staked as specified in Construction Specification 7, Construction Surveys.
- (3) In Section 5, Disposal, Disposal shall be in areas shown on the drawings or as approved by the landowner and Contract Officers Representative. Disposal shall be in compliance with all local, state, and federal regulations.
- (4) In Section 6, Measurement and payment, no separate payment will be made for Stripping. Compensation for Stripping will be included in the payment for Bid Item 1, Earthfill.

# Construction Specification 3—Structure Removal

## 1. Scope

The work shall consist of the removal, salvage, and disposal of structures (including fences) from the designated areas.

## 2. Marking

**Method 1**—Each structure or structure part to be removed will be marked with stakes, flags, paint, or other suitable method.

**Method 2**—The area boundaries from which structures must be removed will be marked using stakes, flags, paint, or other suitable method. Structures to remain undisturbed or to be salvaged will be designated by special markings.

## 3. Removal

**Method 1**—All structures designated for removal in the contract shall be removed to the specified extent and depth.

**Method 2**—Within the areas so marked, all visible and buried structures identified shall be removed to the specified extent and depth.

## 4. Salvage

Structures or structure parts that are designated to be salvaged shall be carefully removed and neatly placed in the specified or approved storage location. Salvaged structures that are capable of being disassembled shall be dismantled into individual members or sections. Such structures shall be neatly and systematically match marked with paint before disassembly. All connectors and other parts shall be marked to indicate their proper location within the structure and shall be fastened to the appropriate structural member or packed in suitable containers.

Material from fences designated to be salvaged shall be placed outside the work area on the property on which the fence was originally located. Fence wire shall be rolled into uniform rolls of suitable size and neatly piled with other salvaged materials. Posts and rails shall be neatly stacked.

## 5. Disposal of refuse materials

Refuse materials resulting from structure removal shall be disposed of in a manner and at locations specified in section 7 of this specification or in an acceptable manner and at locations approved by the contracting officer. Disposal by burning shall be in accordance with local rules and regulations.

## 6. Measurement and payment

**Method 1**—For items of work for which specific unit prices are established by the contract, payment for the removal of each structure unit, except fences, is made at the contract unit price. Fences removed or removed and salvaged are measured to the nearest linear foot. Payment for fence removal or removal and salvage is made at the contract unit prices for each type and size of fence.

Such payment will constitute full compensation for all labor, equipment, tools, applicable permits and associated fees for burning and disposal of refuse, and all other items necessary and incidental to the completion of the work.

**Method 2**—For items of work for which specific lump sum prices are established by the contract, payment for structure removal is made at the contract lump sum price.

Such payment will constitute full compensation for all labor, equipment, tools, applicable permits and associated fees for burning and disposal of refuse, and all other items necessary and incidental to the completion of the work.

**All Methods**—The following provisions apply to all methods of measurement and payment. Compensation for any item of work described in the contract, but not listed as a contract line item number in the bid schedule, is included in the payment for the item of work to which it is made subsidiary. Such items and items to which they are made subsidiary are identified in section 7 of this specification.

## **7. Items of work and construction details**

## 7. Items of work and construction details

Items of work to be performed in conformance with this specification and the construction details are:

### a. Subsidiary Item, Structure Removal

- (1) This item consists of all structure removal required to construct the project as shown on the drawings.
- (2) In Section 2, Marking, there will be no marking of structures to be removed.
- (3) In Section 3, Removal, only structures interfering with the installation of the project shall be removed. This may include abandoned structures and other debris. All structure removal shall be subject to the approval of the Contract Officers Representative.
- (4) In Section 5, Disposal of refuse materials, no disposal will be allowed on site. All structures removed shall be disposed offsite at a location of the contractor's choosing in compliance with all local, state, and federal regulations.
- (5) In Section 6, Measurement and payment, no separate payment will be made for Structure Removal. Compensation for Structure Removal will be included in the payment for Bid Item 1, Earthfill.

# Construction Specification 5—Pollution Control

## 1. Scope

The work consists of installing measures or performing work to control erosion and minimize the production of sediment and other pollutants to water and air from construction activities.

## 2. Material

All material furnished shall meet the requirements of the material specifications listed in section 8 of this specification.

## 3. Erosion and sediment control measures and works

The measures and works shall include, but are not limited to, the following:

**Staging of earthwork activities**—The excavation and moving of soil materials shall be scheduled to minimize the size of areas disturbed and unprotected from erosion for the shortest reasonable time.

**Seeding**—Seeding to protect disturbed areas shall occur as soon as reasonably possible following completion of that earthwork activity.

**Mulching**—Mulching to provide temporary protection of the soil surface from erosion.

**Diversions**—Diversions to divert water from work areas and to collect water from work areas for treatment and safe disposition. They are temporary and shall be removed and the area restored to its near original condition when the diversions are no longer required or when permanent measures are installed.

**Stream crossings**—Culverts or bridges where equipment must cross streams. They are temporary and shall be removed and the area restored to its near original condition when the crossings are no longer required or when permanent measures are installed.

**Sediment basins**—Sediment basins collect, settle, and eliminate sediment from eroding areas from impacting properties and streams below the construction site(s). These basins are temporary and shall be removed and the area restored to its original condition when they are no longer required or when permanent measures are installed.

**Sediment filters**—Straw bale filters or geotextile sediment fences trap sediment from areas of limited runoff. Sediment filters shall be properly anchored to prevent erosion under or around them. These filters are temporary and shall be removed and the area restored to its original condition when they are no longer required or when permanent measures are installed.

**Waterways**—Waterways for the safe disposal of runoff from fields, diversions, and other structures or measures. These works are temporary and shall be removed and the area restored to its original condition when they are no longer required or when permanent measures are installed.

**Other**—Additional protection measures as specified in section 8 of this specification or required by Federal, State, or local government.

## 4. Chemical pollution

The contractor shall provide watertight tanks or barrels or construct a sump sealed with plastic sheets to collect and temporarily contain chemical pollutants, such as drained lubricating or transmission fluids, grease, soaps, concrete mixer washwater, or asphalt, produced as a by-product of the construction activities. Pollutants shall be disposed of in accordance with appropriate State and Federal regulations. At the completion of the construction work, tanks, barrels, and sumps shall be removed and the area restored to its original condition as specified in section 8 of this specification. Sump removal shall be conducted without causing pollution.

Sanitary facilities, such as chemical toilets, or septic tanks shall not be located next to live streams, wells, or springs. They shall be located at a distance sufficient to prevent contamination of any water source. At the completion of construction activities, facilities shall be disposed of without causing pollution as specified in section 8 of this specification.

## **5. Air pollution**

The burning of brush or slash and the disposal of other materials shall adhere to state and local regulations.

Fire prevention measures shall be taken to prevent the start or spreading of wildfires that may result from project activities. Firebreaks or guards shall be constructed and maintained at locations shown on the drawings.

All public access or haul roads used by the contractor during construction of the project shall be sprinkled or otherwise treated to fully suppress dust. All dust control methods shall ensure safe construction operations at all times. If chemical dust suppressants are applied, the material shall be a commercially available product specifically designed for dust suppression and the application shall follow manufacturer's requirements and recommendations. A copy of the product data sheet and manufacturer's recommended application procedures shall be provided to the engineer 5 working days before the first application.

## **6. Maintenance, removal, and restoration**

All pollution control measures and temporary works shall be adequately maintained in a functional condition for the duration of the construction period. All temporary measures shall be removed and the site restored to near original condition.

## **7. Measurement and payment**

**Method 1**—For items of work for which specific unit prices are established in the contract, each item is measured to the nearest unit applicable. Payment for each item is made at the contract unit price for that item. For water or chemical suppressant items used for dust control for which items of work are established in section 8 of this specification, measurement for payment will not include water or chemical suppressants that are used inappropriately or excessive to need. Such payment will constitute full compensation for the completion of the work.

**Method 2**—For items of work for which lump sum prices are established in the contract, payment is made as the work proceeds and supported by invoices presented by the contractor that reflect actual costs. If the total of all progress payments is less than the lump sum contract price for this item, the balance remaining for this item will be included in the final contract payment. Payment of the lump sum contract price will constitute full compensation for completion of the work.

**Method 3**—For items of work for which lump sum prices are established in the contract, payment will be prorated and provided in equal amounts on each monthly progress payment estimate. The number of months used for prorating shall be the number estimated to complete the work as outlined in the contractor's approved construction schedule. The final month's prorate amount will be provided with the final contract payment. Payment as described will constitute full compensation for completion of the work.

**All Methods**—The following provisions apply to all methods of measurement and payment. Compensation for any item of work described in the contract, but not listed in the bid schedule is included in the payment for the item of work to which it is made subsidiary. Such items, and the items to which they are made subsidiary, are identified in section 8 of this specification.

## **8. Items of work and construction details**

## **8. Items of work and construction details**

Items of work to be performed in conformance with this specification and the construction details are:

### a. Subsidiary Item, Pollution Control

- (1) This item consists of all pollution control required to construct this project.
- (2) The contractor shall submit a pollution control plan for approval by the Contract Officers Representative at least 2 days prior to any work. The plan shall show the nature and extent of all pollution control.
- (3) In Section 7, Measurement and payment, no separate payment will be made for Pollution Control. Compensation for Pollution Control will be included in the payment for Bid Item 1, Earthfill.



# Construction Specification 7—Construction Surveys

## 1. Scope

The work consists of performing all surveys, measurements, and computations required by this specification.

## 2. Equipment and material

Equipment for construction surveys shall be of a quality and condition to provide the required accuracy. The equipment shall be maintained in good working order and in proper adjustment at all times. Records of repairs, calibration tests, accuracy checks, and adjustments shall be maintained and be available for inspection by the engineer. Equipment shall be checked, tested, and adjusted as necessary in conformance with manufacturer's recommendations.

Material is field notebooks, stakes, templates, platforms, equipment, spikes, steel pins, tools, and all other items necessary to perform the work specified.

## 3. Quality of work

All work shall follow recognized professional practice and the standards of the industry unless otherwise specified in section 9 of this specification. The work shall be performed to the accuracy and detail appropriate for the type of job. Notes, sketches, and other data shall be complete, recorded neatly, legible, reproducible and organized to facilitate ease in review and allow reproduction of copies for job documentation. Survey equipment that requires little or no manual recording of field data shall have survey information documented as outlined in section 9 of this specification.

All computations shall be mathematically correct and shall include information to identify the bid item, date, and who performed, checked, and approved the computations. Computations shall be legible, complete, and clearly document the source of all information used including assumptions and measurements collected.

If a computer program is used to perform the computations, the contractor shall provide the engineer with the software identification, vendor's name, version number, and other pertinent data before beginning survey activities. Computer generated computations shall show all input data including values assigned and assumptions made.

The elevations of permanent and temporary bench marks shall be determined and recorded to the nearest 0.01 foot. Differential leveling and transit traverses shall be of such precision that the error of vertical closure in feet shall not exceed plus or minus 0.1 times the square root of the traverse distance in miles. Linear measurements shall be accurate to within 1 foot in 5,000 feet, unless otherwise specified in section 9 of this specification. The angular error of closure for transit traverses shall not exceed 1 minute times the square root of the number of angles turned.

The minimum requirements for placing slope stakes shall be at 100-foot stations for tangents, as little as 25 feet for sharp curves, breaks in the original ground surface and at any other intermediate stations necessary to ensure accurate location for construction layout and measurement. Slope stakes and cross sections shall be perpendicular to the centerline. Significant breaks in grade shall be determined for cross sections. Distances shall be measured horizontally and recorded to the nearest 0.1 foot. Side shots for interim construction stakes may be taken with a hand level.

Unless otherwise specified in section 9 of this specification, measurements for stationing and establishing the location of structures shall be made to the nearest 0.1 foot.

Elevations for concrete work, pipes, and mechanical equipment shall be determined and recorded to the nearest 0.01 foot. Elevations for earth work shall be determined and recorded to the nearest 0.1 foot.

#### **4. Primary control**

The baselines and bench marks for primary control, necessary to establish lines and grades needed for construction, are shown on the drawings and have been located on the job site.

These baselines and bench marks shall be used as the origin of all surveys, layouts, and measurements to establish construction lines and grades. The contractor shall take all necessary precautions to prevent the loss or damage of primary control points. Any stakes or control points lost or damaged by construction activity will be reestablished by the contractor or at contractor expense.

#### **5. Construction surveys**

Before work starts that requires contractor performed surveys, the contractor shall submit in writing for the engineer's review: the name, qualifications, and experience of the individuals to be assigned to the survey tasks.

**Method 1**—Contractor performed surveys shall include:

- checking and any supplemental or interim staking
- performing quantity surveys, measurements, and computations for progress payment
- other surveys as described in section 9 of this specification

**Method 2**—Contractor performed surveys shall consist of all work necessary for:

- establishing line and grade for all work
- setting slope stakes for all work
- checking and any supplemental or interim staking
- establishing final grade stakes
- performing quantity surveys, measurements, and computations for progress payment
- other surveys as described in section 9 of this specification

**Method 3**—Contractor performed surveys shall consist of all work necessary for:

- establishing line and grade for all work
- setting slope stakes for all work
- checking and any supplemental or interim staking
- establishing final grade stakes
- performing quantity surveys, measurements, and computations for progress payments
- performing original (initial) and final surveys for determinations of final quantities
- other surveys as described in section 9 of this specification.

#### **6. Staking**

The construction staking required for the item shall be completed before work on any item starts. Construction staking shall be completed as follows or as otherwise specified in section 9 of this specification:

**Clearing and grubbing**—The boundary of the area(s) to be cleared and grubbed shall be staked or flagged at a maximum interval of 200 feet, closer if needed, to clearly mark the limits of work. When contractor staking is the basis for determining the area for final payment, all boundary stakes will be reviewed by the engineer before start of this work item.

**Excavation and fill**—Slope stakes shall be placed at the intersection of the specified slopes and ground line. Slope stakes and the reference stakes for slopes shall be marked with the stationing, required cut or fill, slope ratio, and horizontal distance from the centerline or other control line. The minimum requirements for placing slope stakes is outlined in section 3, Quality of work.

**Structures**—Centerline and offset reference line stakes for location, alignment, and elevation shall be placed for all structures.

## 7. Records

All survey data shall be recorded in fully identified standard hard-bound engineering survey field notebooks with consecutively numbered pages. All field notes and printed data shall include the purpose or description of the work, the date the work was performed, weather data, sketches, and the personnel who performed and checked the work. Electronically generated survey data and computations shall be bound, page numbered, and cross referenced in a bound field notebook containing the index for all survey activities. All work shall follow recognized professional practice.

The construction survey records shall be available at all times during the progress of the work for examination and use by the engineer and when requested, copies shall be made available. The original field notebooks and other records shall be provided to and become the property of the owner before final payment and acceptance of all work.

Complete documentation of computations and supporting data for progress payments shall be submitted to the engineer with each invoice for payment as specified in section 9 of the specification. When the contractor is required to conduct initial and final surveys as outlined in section 5, Construction Surveys, notes shall be provided as soon as possible after completion to the engineer for the purpose of determining final payment quantities.

## 8. Payment

**Method 1**—For items of work for which lump sum prices are established in the contract, payment is made as the work proceeds, after presentation of correct and accurate invoices by the contractor showing related costs and evidence of the charges of suppliers, subcontractors, and others for supplies furnished and work performed. Invoices for the total amount of the contract price will not be accepted until all surveys are complete and required documentation has been determined complete. If the total of such payments is less than the lump sum contract price for this item, the unpaid balance will be included in the final contract payment. Payment of the lump sum contract price will constitute full compensation for completion of all work under the bid item.

**Method 2**—For items of work for which lump sum prices are established in the contract, payment is made as the work proceeds with progress payment amounts determined as a percentage of the total work planned as projected from the contractor's approved construction schedule. Payment of the lump sum contract price will constitute full compensation for completion of all work under this bid item.

**All Methods**—Payment will not be provided under this item for the purchase price of materials or equipment having a residual value.

Compensation for any item of work described in the contract, but not listed in the bid schedule will be included in the payment for the item of work to which it is made subsidiary. Such items and the item to which they are made subsidiary are identified in section 9 of this specification.

## 9. Items of work and construction details

## 9. Items of work and construction details

Items of work to be performed in conformance with this specification and the construction details are:

### a. Subsidiary Item, Construction Surveys

- (1) This item consists of all surveys required to construct the project as shown on the drawings.
- (2) In Section 5, Construction surveys, method 2 shall apply. The Conservation District will establish the beginning and ending location of the protection berm, drivable dip, road raise and/or flexible bulk container as applicable for each site.
- (3) In Section 8, Payment, no separate payment will be made for Construction Surveys. Compensation for Construction Surveys will be included in the payment for Bid Item 1, Earthfill.

# Construction Specification 8—Mobilization and Demobilization

## **1. Scope**

The work consists of the mobilization and demobilization of the contractor's forces and equipment necessary for performing the work required under the contract. It does not include mobilization and demobilization for specific items of work for which payment is provided elsewhere in the contract. Mobilization will not be considered as work in fulfilling the contract requirements for commencement of work.

## **2. Equipment and material**

Mobilization shall include all activities and associated costs for transportation of contractor's personnel, equipment, and operating supplies to the site; establishment of offices, buildings, and other necessary general facilities for the contractor's operations at the site; premiums paid for performance and payment bonds including coinsurance and reinsurance agreements as applicable; and other items specified in section 4 of this specification.

Demobilization shall include all activities and costs for transportation of personnel, equipment, and supplies not required or included in the contract from the site; including the disassembly, removal, and site cleanup of offices, buildings, and other facilities assembled on the site specifically for this contract.

This work includes mobilization and demobilization required by the contract at the time of award. If additional mobilization and demobilization activities and costs are required during the performance of the contract as a result of changed, deleted, or added items of work for which the contractor is entitled to an adjustment in contract price, compensation for such costs will be included in the price adjustment for the item or items of work changed or added.

## **3. Payment**

Payment will be made as the work proceeds, after presentation of paid invoices or documentation of direct costs by the contractor showing specific mobilization and demobilization costs and supporting evidence of the charges of suppliers, subcontractors, and others. When the total of such payments is less than the lump sum contract price, the balance remaining will be included in the final contract payment. Payment of the lump sum contract price for mobilization and demobilization will constitute full compensation for completion of the work.

Payment will not be made under this item for the purchase costs of materials having a residual value, the purchase costs of materials to be incorporated in the project, or the purchase costs of operating supplies.

## **4. Items of work and construction details**

#### **4. Items of work and construction details**

Items of work to be performed in conformance with this specification and the construction details are:

a. Subsidiary Item, Mobilization and Demobilization

- (1) This item consists of all mobilization and demobilization required for this project.
- (2) Measurement and payment, no separate payment will be made for Mobilization and Demobilization. Compensation for Mobilization and Demobilization will be included the payment for Bid Item 1, Earthfill.

# Construction Specification 10—Water for Construction

## 1. Scope

The work consists of furnishing, transporting, measuring, and applying water as specified.

## 2. Facilities and equipment

The contractor shall install and maintain access and haul roads and furnish, operate, and maintain all pumps, meters, piping, tanks, storage, and other facilities required to load, transport, store, distribute, and use construction water as specified.

These facilities shall be equipped with accurate, work dedicated meters; tanks of known volume; or other devices that provide a correct measurement of water supplied. Meters shall be installed at the point of delivery into water hauling equipment or application system, such as sprinkler systems or flooding systems, as specified.

## 3. Dust abatement and haul road maintenance

Water for dust abatement and haul road maintenance shall be applied to haul roads and other dust producing areas as needed to prevent air pollution or excessive dust (which causes impaired vision on trafficked roads and in work areas) and to maintain the roads in good condition for safe and efficient operation during periods of use. Roads that may be jointly used with the public and by the contractor's equipment shall have dust abatement provisions acceptable to the public entity that has road maintenance responsibility. Compensation for water used for dust abatement and haul road maintenance shall be as specified in section 8 of this specification.

## 4. Earthfill, drainfill, and rockfill

Water required for proper installation of earthfill, drainfill, and/or rockfill shall be used in the fill materials as specified in the applicable construction specification(s). Compensation for construction water used for earthfill, drainfill, and/or rockfill shall be as specified in section 8 of this specification.

## 5. Concrete, mortar, and grout

Water required in the mixing or curing of concrete, shotcrete, roller compacted concrete, or other portland cement mortar or grout shall meet the requirements of the applicable construction specifications and shall be used in conformance with those specifications. Payment for construction water used in these items is covered by the applicable concrete, mortar, or grout specification, or a combination of these.

## 6. Other construction requiring water

Water required and used for other construction activities under this contract, but not specifically covered by this specification shall be considered subsidiary to the item(s) of work that requires its use.

## 7. Measurement and payment

**Method 1**—For water items for which specific unit prices are established in the contract, the volume of water furnished and used in accordance with the specifications will be measured to the nearest 1,000 gallons.

Payment for water is made at the contract unit price. Such payment will constitute full compensation for the direct costs of water. All other costs necessary for transportation, distribution, and application are subsidiary to the items of work with which they are associated.

**Method 2**—For water items for which specific unit prices are established in the contract, the volume of water furnished and used in accordance with the specifications will be measured to the nearest 1,000 gallons.

Payment for water and the cost associated with transportation, distribution, and application is made at the contract unit price. Such payment will constitute full compensation for completion of the work.

**Method 3**—For water items for which specific unit prices are established in the contract, the volume of water used in accordance with the specifications will be measured to the nearest 1,000 gallons.

Payment for water is made at the contract unit price. Such payment, excluding water cost, will constitute full compensation for completion of the work.

**All methods**—The following provisions apply to all methods of measurement and payment:

- The measurement for payment will include all water used except as noted in sections 5, 6, and 8 of this specification. Measurement for payment will not include water that is used inappropriately or in excess of that needed to accomplish the specified task.
- Compensation for any item of work described in the contract, but not listed in the bid schedule is included in the payment for the item of work to which it is made subsidiary. Such items and the items to which they are made subsidiary are identified in section 8 of this specification.

## **8. Items of work and construction details**



## **8. Items of work and construction details**

Items of work to be performed in conformance with this specification and the construction details are:

### a. Subsidiary Item, Water for Construction

- (1) This item shall consist of supplying and applying water for dust control, haul road maintenance, and maintaining the moisture content of earthfill and base fill during compaction to the lines and grades as shown on the drawings.
- (2) In Section 7, Measurement and Payment, no separate payment will be made for Water for Construction. Compensation for Water for Construction will be included the payment for Bid Item 1, Earthfill.

# Construction Specification 11—Removal of Water

## **1. Scope**

The work consists of the removal of surface water and ground water as necessary to perform the construction required by the contract in accordance with the specifications. It shall include: (1) constructing, installing, building, and maintaining all necessary temporary water containment facilities, channels, and diversions; (2) furnishing, installing, and operating all necessary pumps, piping, and other facilities and equipment; and (3) removing all such temporary works and equipment after their intended function is no longer required.

## **2. Diverting surface water**

The contractor shall install, maintain, and operate all cofferdams, channels, flumes, sumps, and all other temporary diversion and protective works needed to divert streamflow and other surface water through or around the construction site. Control of surface water shall be continuous during the period that damage to construction work could occur. Unless otherwise specified and/or approved, the diversion outlet shall be into the same drainageway that the water would have reached before being diverted.

The contractor shall furnish the contracting officer, in writing, a proposed plan for diverting surface water before beginning any construction activities for which a diversion is required, unless waived in section 8 of this specification. Acceptance of this plan or the waiving of the plan requirement will not relieve the contractor of the responsibilities related to this activity during the process of completing the work as specified.

## **3. Dewatering the construction site**

Foundations, cutoff trenches, and all other parts of the construction site shall be dewatered and kept free of standing water and muddy conditions as necessary for the proper execution of the work. The contractor shall furnish, install, operate, and maintain all drains, sumps, pumps, casings, well points, and all other equipment required to properly dewater the site as specified. Dewatering systems that cause a loss of soil fines from the foundation areas will not be permitted.

The contractor shall furnish the contracting officer, in writing, a proposed plan for dewatering before commencing with any construction activity for which dewatering may be required, unless waived in section 8 of this specification. Acceptance of this plan or the waiving of the plan requirement will not relieve the contractor of the responsibilities for completing the specified work.

## **4. Dewatering borrow areas**

The contractor shall maintain all borrow areas free of surface water or otherwise provide for timely and effective removal of surface and subsurface water that accumulates within the borrow area, unless waived in section 8 of this specification. Borrow material shall be processed as necessary to achieve proper and uniform moisture content at the time of placement.

If pumping to dewater borrow areas is included as a bid item of work in the bid schedule, each pump discharge pipe shall be equipped with a water meter. The meter shall be such that the measured quantity of water is accurate within 3 percent of the true quantity. The contractor shall provide necessary support to perform accuracy tests of the water meter when requested by the contracting officer.

## **5. Erosion and pollution control**

Removal of water from the construction site, including the borrow areas, shall be accomplished so that erosion and the transporting of sediment and other pollutants are minimized. Dewatering activities shall be accomplished in a manner that the water table water quality is not altered. Pollution control activities

shall not conflict with the requirements of Construction Specification 5, Pollution Control, if it is a part of this contract.

## **6. Removal of temporary works**

When temporary works are no longer needed, the contractor shall remove and return the area to a condition similar to that which existed before construction. Areas where temporary works were located shall be graded for slightly appearance with no obstruction to natural surface waterflows or the proper functioning and access to the works of improvement installed. The contractor shall exercise extreme care during the removal stages to minimize the loss of soil sediment and debris that was trapped during construction.

Pipes, casings, and any other material used to dewater the site shall be removed from temporary wells. The wells shall be filled to ground level with clean gravel or other suitable material approved by the contracting officer. The contractor shall exercise extreme care to prevent pollution of the ground water by these actions.

## **7. Measurement and payment**

**Method 1**—Items of work listed in the bid schedule for removal of water, diverting surface water, and dewatering construction sites and borrow areas are paid for at the contract lump sum prices. Such payment will constitute full compensation for all labor, equipment, tools, and all other items necessary and incidental to the completion of the work.

**Method 2**—Items of work listed in the bid schedule for removal of water, diverting surface water, dewatering construction sites, and dewatering borrow areas are paid for at the contract lump sum prices. Such payment will constitute full compensation for furnishing, installing, operating, and maintaining the necessary trenches, drains, sumps, pumps, and piping and for all labor, equipment, tools, and all other items necessary and incidental to the completion of the work. The exception is that additional payment for pumping to dewater borrow areas and the removal of water will be made as described in the following paragraph.

If pumping to dewater borrow areas is a contract bid item, payment is made at the contract unit price, which shall be the price per 1,000 gallons shown in the bid schedule. Such payment will constitute full compensation for pumping only. Compensation for equipment and preparation and for other costs associated with pumping is included in the lump sum payment for removal of water or the lump sum payment for dewatering the borrow areas. Payment is made only for pumping that is necessary to dewater borrow areas that cannot be effectively drained by gravity or that must have the water table lowered to be usable as a suitable borrow source. Pumping for other purposes will not be included for payment under this item.

**All Methods**—The following provisions apply to all methods of measurement and payment. Compensation for any item of work described in the contract, but not listed in the bid schedule is included in the payment for the contract line item to which it is made subsidiary. Such items and the items to which they are made subsidiary are identified in section 8 of this specification.

## **8. Items of work and construction details**

## 7. Items of work and construction details

Items of work to be performed in conformance with this specification and the construction details are:

### a. Subsidiary Item, Removal of Water

- (1) This item shall consist of all work required to divert surface water and dewater the work site so that construction of the permanent works of improvement can be performed under dry and stable conditions.
- (2) The dewatering facilities shall be adequate to keep the work site dewatered during construction.
- (3) Following dewatering, the soil shall be allowed to dry out to the extent necessary to permit construction activities to proceed in a dry, stable condition.
- (4) The contractor shall submit a plan for approval by the Contract Officers Representative for diverting surface water and dewatering the work site. The plan shall be submitted a minimum of two (2) days prior to beginning work.
- (5) In Section 7, Measurement and payment, no separate payment will be made for Removal of Water. Compensation for Removal of Water will be included in the payment for Bid Item 1, Earthfill.

# Construction Specification 21—Excavation

## 1. Scope

The work shall consist of the excavation required by the drawings and specifications and disposal of the excavated materials.

## 2. Classification

Excavation is classified as **common excavation**, **rock excavation**, or **unclassified excavation** in accordance with the following definitions.

**Common excavation** is defined as the excavation of all materials that can be excavated, transported, and unloaded using heavy ripping equipment and wheel tractor-scrapers with pusher tractors or that can be excavated and dumped into place or loaded onto hauling equipment by excavators having a rated capacity of one cubic yard or larger and equipped with attachments (shovel, bucket, backhoe, dragline, or clam shell) appropriate to the material type, character, and nature of the materials.

**Rock excavation** is defined as the excavation of all hard, compacted, or cemented materials that require blasting or the use of ripping and excavating equipment larger than defined for common excavation. The excavation and removal of isolated boulders or rock fragments larger than 1 cubic yard encountered in materials otherwise conforming to the definition of common excavation shall be classified as rock excavation. The presence of isolated boulders or rock fragments larger than 1 cubic yard is not in itself sufficient cause to change the classification of the surrounding material.

For the purpose of these classifications, the following definitions shall apply:

*Heavy ripping equipment* is a rear-mounted, heavy duty, single-tooth, ripping attachment mounted on a track type tractor having a power rating of at least 250 flywheel horsepower unless otherwise specified in section 10.

*Wheel tractor-scraper* is a self-loading (not elevating) and unloading scraper having a struck bowl capacity of at least 12 cubic yards.

*Pusher tractor* is a track type tractor having a power rating of at least 250 flywheel horsepower equipped with appropriate attachments.

**Unclassified excavation** is defined as the excavation of all materials encountered, including rock materials, regardless of their nature or the manner in which they are removed.

## 3. Blasting

The transportation, handling, storage, and use of dynamite and other explosives shall be directed and supervised by a person(s) of proven experience and ability who is authorized and qualified to conduct blasting operations.

Blasting shall be done in a manner as to prevent damage to the work or unnecessary fracturing of the underlying rock materials and shall conform to any special requirements in section 10 of this specification. When specified in section 10, the contractor shall furnish the engineer, in writing, a blasting plan before blasting operations begin.

#### **4. Use of excavated material**

**Method 1**—To the extent they are needed, all suitable material from the specified excavations shall be used in the construction of required permanent earthfill or rockfill. The suitability of material for specific purposes is determined by the engineer. The contractor shall not waste or otherwise dispose of suitable excavated material.

**Method 2**—Suitable material from the specified excavations may be used in the construction of required earthfill or rockfill. The suitability of material for specific purposes is determined by the engineer.

#### **5. Disposal of waste materials**

**Method 1**—All surplus or unsuitable excavated materials are designated as waste and shall be disposed of at the locations shown on the drawings.

**Method 2**—All surplus or unsuitable excavated materials are designated as waste and shall be disposed of by the contractor at sites of his own choosing away from the site of the work. The disposal shall be in an environmentally acceptable manner that does not violate local rules and regulations.

#### **6. Excavation limits**

Excavations shall comply with OSHA Construction Industry Standards (29CFR Part 1926) Subpart P, Excavations, Trenching, and Shoring. All excavations shall be completed and maintained in a safe and stable condition throughout the total construction phase. Structure and trench excavations shall be completed to the specified elevations and to the length and width required to safely install, adjust, and remove any forms, bracing, or supports necessary for the installation of the work. Excavations outside the lines and limits shown on the drawings or specified herein required to meet safety requirements shall be the responsibility of the contractor in constructing and maintaining a safe and stable excavation.

#### **7. Borrow excavation**

When the quantities of suitable material obtained from specified excavations are insufficient to construct the specified earthfills and earth backfills, additional material shall be obtained from the designated borrow areas. The extent and depth of borrow pits within the limits of the designated borrow areas shall be as specified in section 10 or as approved by the engineer.

Borrow pits shall be excavated and finally dressed to blend with the existing topography and sloped to prevent ponding and to provide drainage.

#### **8. Overexcavation**

Excavation in rock beyond the specified lines and grades shall be corrected by filling the resulting voids with portland cement concrete made of materials and mix proportions approved by the engineer. Concrete that will be exposed to the atmosphere when construction is completed shall meet the requirements of concrete selected for use under Construction Specification 31, Concrete for Major Structures, or 32, Structure Concrete, as appropriate.

Concrete that will be permanently covered shall contain not less than five bags of cement per cubic yard. The concrete shall be placed and cured as specified by the engineer.

Excavation in earth beyond the specified lines and grades shall be corrected by filling the resulting voids with approved, compacted earthfill. The exception to this is that if the earth is to become the subgrade for riprap, rockfill, sand or gravel bedding, or drainfill, the voids may be filled with material conforming to the specifications for the riprap, rockfill, bedding, or drainfill. Before correcting an overexcavation condition, the contractor shall review the planned corrective action with the engineer and obtain approval of the corrective measures.

## **9. Measurement and payment**

For items of work for which specific unit prices are established in the contract, the volume of each type and class of excavation within the specified pay limits is measured and computed to the nearest cubic yard by the method of average cross-sectional end areas or by methods outlined in section 10 of this specification. Regardless of quantities excavated, the measurement for payment is made to the specified pay limits except that excavation outside the specified lines and grades directed by the engineer to remove unsuitable material is included. Excavation required because unsuitable conditions result from the contractor's improper construction operations, as determined by the engineer, is not included for measurement and payment.

**Method 1**—The pay limits shall be as designated on the drawings.

**Method 2**—The pay limits shall be defined as follows:

- a. The upper limit shall be the original ground surface as it existed before the start of construction operations except that where excavation is performed within areas designated for previous excavation or earthfill, the upper limit shall be the modified ground surface resulting from the specified previous excavation or earthfill.
- b. The lower and lateral limits shall be the neat lines and grades shown on the drawings.

**Method 3**—The pay limits shall be defined as follows:

- a. The upper limit shall be the original ground surface as it existed before the start of construction operations except that where excavation is performed within areas designated for previous excavation or earthfill, the upper limit shall be the modified ground surface resulting from the specified previous excavation or earthfill.
- b. The lower and lateral limits shall be the true surface of the completed excavation as directed by the engineer.

**Method 4**—The pay limits shall be defined as follows:

- a. The upper limit shall be the original ground surface as it existed before the start of construction operations except that where excavation is performed within areas designated for previous excavation or earthfill, the upper limit shall be the modified ground surface resulting from the specified previous excavation or earthfill.
- b. The lower limit shall be at the bottom surface of the proposed structure.
- c. The lateral limits shall be 18 inches outside of the outside surface of the proposed structure or shall be vertical planes 18 inches outside of and parallel to the footings, whichever gives the larger pay quantity, except as provided in d below.
- d. For trapezoidal channel linings or similar structures that are to be supported upon the sides of the excavation without intervening forms, the lateral limits shall be at the underside of the proposed lining or structure.
- e. For the purposes of the definitions in b, c, and d, above, any specified bedding or drainfill directly beneath or beside the structure will be considered to be a part of the structure.

**All methods**—The following provisions apply to all methods of measurement and payment.

Payment for each type and class of excavation is made at the contract unit price for that type and class of excavation. Such payment will constitute full compensation for all labor, materials, equipment, and all other items necessary and incidental to the performance of the work except that extra payment for backfilling overexcavation will be made in accordance with the following provisions.

Payment for backfilling overexcavation, as specified in section 8 of this specification, is made only if the excavation outside specified lines and grades is directed by the engineer to remove unsuitable material and if the unsuitable condition is not a result of the contractor's improper construction operations as determined by the engineer.

Compensation for any item of work described in the contract, but not listed in the bid schedule is included in the payment for the item of work to which it is made subsidiary. Such items and the items to which they are made subsidiary are identified in section 10 of this specification.

## **10. Items of work and construction details**



## 10. Items of work and construction details

Items of work to be performed in conformance with this specification and the construction details are:

a. Subsidiary Item , Excavation, Unclassified

- (1) This item shall consist of all excavation required to construct the protection berm, drivable dip, road raise and other associated works to the lines and grades shown on the drawings. This shall be limited to a maximum of 1-foot depth required for stripping.
- (2) If any archeological items are found during excavation, work at that location shall cease immediately and the contractor shall contact the Contract Officers Representative. Work shall not continue until and unless authorized by the Contract Officers Representative.
- (3) In Section 2, Classification, the definition for *Unclassified excavation* applies to this item.
- (4) In Section 4, Use of excavated material, Method 2 shall apply.
- (5) In Section 5, Disposal of waste materials, Method 2 shall apply.
- (6) In Section 9, Measurement and payment, no separate payment will be made for Excavation, Unclassified. Compensation for Excavation, Unclassified will be included in Bid Item 1, Earthfill.

# Construction Specification 23—Earthfill

## 1. Scope

The work consists of the construction of earth embankments, other earthfills, and earth backfills required by the drawings and specifications.

Earthfill is composed of natural earth materials that can be placed and compacted by construction equipment operated in a conventional manner.

Earth backfill is composed of natural earth material placed and compacted in confined spaces or adjacent to structures (including pipes) by hand tamping, manually directed power tampers or vibrating plates, or their equivalent.

## 2. Material

All fill material shall be obtained from required excavations and designated borrow areas. The selection, blending, routing, and disposition of material in the various fills shall be subject to approval by the engineer.

Fill materials shall contain no frozen soil, sod, brush, roots, or other perishable material. Rock particles larger than the maximum size specified for each type of fill shall be removed prior to compaction of the fill.

The types of material used in the various fills shall be as listed and described in the specifications and drawings.

## 3. Foundation preparation

Foundations for earthfill shall be stripped to remove vegetation and other unsuitable material or shall be excavated as specified.

Except as otherwise specified, earth foundation surfaces shall be graded to remove surface irregularities and shall be scarified parallel to the axis of the fill or otherwise acceptably scored and loosened to a minimum depth of 2 inches. The moisture content of the loosened material shall be controlled as specified for the earthfill, and the surface material of the foundation shall be compacted and bonded with the first layer of earthfill as specified for subsequent layers of earthfill.

Earth abutment surfaces shall be free of loose, uncompacted earth in excess of 2 inches in depth normal to the slope and shall be at such a moisture content that the earthfill can be compacted against them to produce a good bond between the fill and the abutments.

Rock foundation and abutment surfaces shall be cleared of all loose material by hand or other effective means and shall be free of standing water when fill is placed upon them. Occasional rock outcrops in earth foundations for earthfill, except in dams and other structures designed to restrain the movement of water, shall not require special treatment if they do not interfere with compaction of the foundation and initial layers of the fill or the bond between the foundation and the fill.

Foundation and abutment surfaces shall be no steeper than one horizontal to one vertical unless otherwise specified. Test pits or other cavities shall be filled with compacted earthfill conforming to the specifications for the earthfill to be placed upon the foundation.

#### **4. Placement**

Earthfill shall not be placed until the required excavation and foundation preparation have been completed and the foundation has been inspected and approved by the engineer. Earthfill shall not be placed upon a frozen surface nor shall snow, ice, or frozen material be incorporated in the earthfill matrix.

Earthfill shall be placed in approximately horizontal layers. The thickness of each layer before compaction shall not exceed the maximum thickness specified in section 10 or shown on the drawings. Materials placed by dumping in piles or windrows shall be spread uniformly to not more than the specified thickness before being compacted.

Hand compacted earth backfill shall be placed in layers whose thickness before compaction does not exceed the maximum thickness specified for layers of earth backfill compacted by manually directed power tampers.

Earth backfill shall be placed in a manner that prevents damage to the structures and allows the structures to assume the loads from the earth backfill gradually and uniformly. The height of the earth backfill adjacent to a structure shall be increased at approximately the same rate on all sides of the structure.

Earthfill and earth backfill in dams, levees, and other structures designed to restrain the movement of water shall be placed to meet the following additional requirements:

- (a) The distribution of materials throughout each zone shall be essentially uniform, and the earthfill shall be free from lenses, pockets, streaks, or layers of material differing substantially in texture, moisture content, or gradation from the surrounding material. Zone earthfills shall be constructed concurrently unless otherwise specified.
- (b) The surface of each layer shall be scarified parallel to the axis of the fill to a depth of not less than 2 inches before the next layer is placed.
- (c) The top surface of embankments shall be maintained approximately level during construction with two exceptions: A crown or cross-slope of about 2 percent shall be maintained to ensure effective drainage, or as otherwise specified for drainfill or sectional zones.
- (d) Dam embankments shall be constructed in continuous layers from abutment to abutment except where openings to facilitate construction or to allow the passage of streamflow during construction are specifically authorized in the contract.
- (e) Embankments built at different levels as described under (c) or (d) above shall be constructed so that the slope of the bonding surfaces between embankment in place and embankment to be placed is not steeper than 3 feet horizontal to 1 foot vertical. The bonding surface of the embankment in place shall be stripped of all material not meeting the requirements of this specification and shall be scarified, moistened, and recompacted when the new earthfill is placed against it. This ensures a good bond with the new earthfill and obtains the specified moisture content and density at the contact of the in-place and new earthfills.

#### **5. Control of moisture content**

During placement and compaction of earthfill and earth backfill, the moisture content of the material being placed shall be maintained within the specified range.

The application of water to the earthfill material shall be accomplished at the borrow areas insofar as practicable. Water may be applied by sprinkling the material after placement on the earthfill, if necessary. Uniform moisture distribution shall be obtained by disking.

Material that is too wet when deposited on the earthfill shall either be removed or be dried to the specified moisture content prior to compaction.

If the top surface of the preceding layer of compacted earthfill or a foundation or abutment surface in the zone of contact with the earthfill becomes too dry to permit suitable bond, it shall either be removed or scarified and moistened by sprinkling to an acceptable moisture content before placement of the next layer of earthfill.

## 6. Compaction

**Earthfill**—Earthfill shall be compacted according to the following requirements for the class of compaction specified:

**Class A compaction**—Each layer of earthfill shall be compacted as necessary to provide the density of the earthfill matrix not less than the minimum density specified in Section 10 or identified on the drawings. The earthfill matrix is defined as the portion of the earthfill material finer than the maximum particle size allowed in the reference compaction test method specified (ASTM D698 or ASTM D1557).

**Class B compaction**—Each layer of earthfill shall be compacted to a mass density not less than the minimum density specified.

**Class C compaction**—Each layer of earthfill shall be compacted by the specified number of passes of the type and weight of roller or other equipment specified or by an approved equivalent method. Each pass shall consist of at least one passage of the roller wheel or drum over the entire surface of the layer.

**Earth backfill**—Earth backfill adjacent to structures shall be compacted to a density equivalent to that of the surrounding in-place earth material or adjacent required earthfill or earth backfill. Compaction shall be accomplished by hand tamping or manually directed power tampers, plate vibrators, walk-behind, miniature, or self-propelled rollers. Unless otherwise specified heavy equipment including backhoe mounted power tampers or vibrating compactors and manually directed vibrating rollers shall not be operated within 3 feet of any structure. Towed or self-propelled vibrating rollers shall not be operated within 5 feet of any structure. Compaction by means of drop weights operating from a crane or hoist is not permitted.

The passage of heavy equipment will not be allowed:

- Over cast-in-place conduits within 14-days after placement of the concrete
- Over cradled or bedded precast conduits within 7 days after placement of the concrete cradle or bedding
- Over any type of conduit until the backfill has been placed above the top surface of the structure to a height equal to one-half the clear span width of the structure or pipe or 3 feet, whichever is greater, except as may be specified in section 10.

Compacting of earth backfill adjacent to structures shall not be started until the concrete has attained the strength specified in section 10 for this purpose. The strength is determined by compression testing of test cylinders cast by the contractor's quality control personnel for this purpose and cured at the work site in the manner specified in ASTM C 31 for determining when a structure may be put into service.

When the required strength of the concrete is not specified as described above, compaction of earth backfill adjacent to structures shall not be started until the following time intervals have elapsed after placement of the concrete.

| Structure  | Time interval<br>(days) |
|--|-------------------------|
| Vertical or near-vertical walls with earth loading on one side only      | 14                      |
| Walls backfilled on both sides simultaneously                            | 7                       |
| Conduits and spillway risers, cast-in-place (with inside forms in place) | 7                       |
| Conduits and spillway risers, cast-in-place (inside forms removed)       | 14                      |
| Conduits, pre-cast, cradled  | 2                       |
| Conduits, pre-cast, bedded   | 1                       |
| Cantilever outlet bents (backfilled both sides simultaneously)           | 3                       |

### 7. Reworking or removal and replacement of defective earthfill

Earthfill placed at densities lower than the specified minimum density or at moisture contents outside the specified acceptable range of moisture content or otherwise not conforming to the requirements of the specifications shall be reworked to meet the requirements or removed and replaced by acceptable earthfill. The replacement earthfill and the foundation, abutment, and earthfill surfaces upon which it is placed shall conform to all requirements of this specification for foundation preparation, approval, placement, moisture control, and compaction.

### 8. Testing

During the course of the work, the contractor shall perform quality control tests, as applicable, to identify earthfill and earth backfill materials; determine the reference maximum density and optimum moisture content; and document that the moisture content of material at the time of compaction and the density of earthfill and earth backfill in place conform to the requirements of this specification.

*Determining Reference Maximum Density and Optimum Moisture Content*—For Class A compaction, the reference maximum density and optimum moisture content shall be determined in accordance with the compaction test and method specified on the drawings or in section 10.

*Documenting Specification Conformance*—In-place densities of earthfill and earth backfill requiring Class A compaction shall be measured in accordance with ASTM D1556, D2167, D2937, or D6938. Moisture contents of earthfill and earth backfill at the time of compaction shall be measured in accordance with ASTM D2216, D4643, or D6938. Values of moisture content determined by ASTM D2216 are considered the true value of the soil moisture. Values of moisture content determined by ASTM D4643 or D6938 shall be verified by comparison to values obtained by ASTM D2216. Values of in-place density and moisture content determined by these tests shall be compared to the minimum density and moisture content range specified on the drawings or in section 10.

*Correction for Oversize Particles*—If the materials to be used for earthfill or earth backfill contain more than 5 percent by dry weight of oversize rock particles (particles larger than those allowed in the specified compaction test and method), corrections for oversize particles shall be made using the appropriate procedures explained in ASTM D4718.

### 9. Measurement and payment

For items of work for which specific unit prices are established in the contract, the volume of each type and compaction class of earthfill and earth backfill within the specified zone boundaries and pay limits is measured and computed to the nearest cubic yard by the method of average cross-sectional end areas. Unless otherwise specified in section 10, no deduction in volume is made for embedded items, such as, but not limited to, conduits, inlet structures, outlet structures, embankment drains, sand diaphragm and outlet, and their appurtenances.

The pay limits shall be as defined below, with the further provision that earthfill required to fill voids resulting from overexcavation of the foundation, outside the specified lines and grades, will be included in the measurement for payment only under the following conditions:

- Where such overexcavation is directed by the engineer to remove unsuitable material, and
- Where the unsuitable condition is not a result of the contractor's improper construction operations as determined by the engineer.

Earthfill beyond the specified lines and grades to backfill excavation required for compliance with OSHA requirements will be considered subsidiary to the earthfill bid item(s).

**Method 1**—The pay limits shall be as designated on the drawings.

**Method 2**—The pay limits shall be the measured surface of the foundation when approved for placement of the earthfill and the specified neat lines of the earthfill surface.

**Method 3**—The pay limits shall be the measured surface of the foundation when approved for placement of the earthfill and the measured surface of the completed earthfill.

**Method 4**—The pay limits shall be the specified pay limits for excavation and the specified neat lines of the earthfill surface.

**Method 5**—The pay limits shall be the specified pay limits for excavation and the measured surface of the completed earthfill.

**Method 6**—Payment for each type and compaction class of earthfill and earth backfill is made at the contract unit price for that type and compaction class of earthfill. Such payment will constitute full compensation for all labor, material, equipment, and all other items necessary and incidental to the performance of the work.

**Method 7**—Payment for each type and compaction class of earthfill and earth backfill is made at the contract unit price for that type and compaction class of earthfill. Such payment will constitute full compensation for all labor, material, equipment, and all other items necessary and incidental to the performance of the work except furnishing, transporting, and applying water to the foundation and earthfill material. Water applied to the foundation and earthfill material is measured and payment made as specified in Construction Specification 10.

**All methods**—The following provisions apply to all methods of measurement and payment. Compensation for any item of work described in the contract, but not listed in the bid schedule is included in the payment for the item of work to which it is made subsidiary. Such items and the items to which they are made subsidiary are identified in section 10 of this specification.

## **10. Items of work and construction details**

## 10. Items of work and construction details

Items of work to be performed in conformance with this specification and the construction details are:

a. Bid Item 1, Earthfill

- (1) This item consists of furnishing, processing, and placing all earth fill associated with the construction of protection berm and other associated works to the lines and grades as shown on the drawings.
- (2) In Section 2, Material, backfill materials shall be GM, GC, SC, or SM in accordance with the Uniform Soil Classification System. The materials shall be free of brush, roots, sod, and other debris. Gravel not meeting the above gradation may be an acceptable material meeting Construction Specification 61.

The Contractor will be required to choose from a previously approved source. The material at this source is subject to the approval of the Contract Officers Representative. It shall be the Contractor's responsibility to obtain all necessary easements and permits for obtaining materials.

- (3) In Section 4, Placement, the maximum thickness before compaction shall not exceed twelve (12) inches.
- (4) In Section 5, Control of moisture content, the moisture content of the material incorporated in the fill shall be maintained within a range allowable for compaction of that material. If the material is too wet or too dry, it shall be reworked or removed from the site.
- (5) In Section 6, Compaction, Class C shall apply. Compaction shall be accomplished using three (3) passes of rubber-tired equipment or rollers weighing not less than four (4) tons.
- (6) Items of work subsidiary to this bid item are:

Stripping, Construction Specification 2  
Structure Removal, Construction Specification 3  
Pollution Control, Construction Specification 5  
Construction Surveys, Construction Specification 7  
Mobilization and Demobilization, Construction Specification 8  
Water for Construction, Construction Specification 10  
Removal of Water, Construction Specification 11  
Excavation, Uncommon, Construction Specification 21  
Road Surfacing, Construction Specification 24  
6-Inch Minus Rock, Construction Specification 61  
10-Inch Minus Loose Rock Riprap, Construction Specification 61  
Contractor Quality Control, Construction Specification 94

- (7) In Section 9, Measurement and payment, no method applies. Compensation for Bid Item 1, Earthfill will be lump sum and will constitute full payment for this item and the related subsidiary item listed above.



# Construction Specification 24—Drainfill

## **1. Scope**

The work consists of furnishing, placing, and compacting drainfill required in the construction of structure drainage systems.

## **2. Material**

**Method 1**—Drainfill material shall conform to the requirements of Material Specification 521, Aggregates for Drainfill and Filters. A minimum of 30 days before delivery of materials to the site, the contractor shall inform the engineer in writing of the source(s) from which drainfill material will be obtained. The contractor shall provide the engineer free access to the source(s) for the purpose of obtaining samples for testing.

**Method 2**—Drainfill material shall be sand, gravel, or crushed stone, or mixtures thereof, obtained from the specified sources. The material shall be selected as necessary to avoid the inclusion of organic matter, clay balls, excessive fine particles, or other substances that would interfere with their free-draining properties.

## **3. Base preparation**

Foundation surface and trenches shall be clean and free of organic matter, loose soil, foreign substance, and standing water when the drainfill is placed. Earth surfaces upon or against which drainfill will be placed shall not be scarified.

## **4. Placement**

Drainfill shall not be placed until the subgrade has been inspected and approved by the engineer. Drainfill shall not be placed over or around pipe or drain tile until the installation of the pipe or tile has been inspected and approved.

Drainfill shall be placed uniformly in layers not to exceed 12 inches thick before compaction. When compaction is accomplished by manually controlled equipment, the layers shall not exceed 8 inches thick. The material shall be placed to avoid segregation of particle sizes and to ensure the continuity and integrity of all zones. No foreign material shall be allowed to become intermixed with or otherwise contaminate the drainfill.

Traffic shall not be permitted to cross over drains at random. Equipment cross-overs shall be maintained, and the number and location of such crossovers shall be established and approved before the beginning of drainfill placement. Each crossover shall be cleaned of all contaminating material and shall be inspected and approved by the engineer before the placement of additional drainfill material.

Any damage to the foundation surface or the trench sides or bottom occurring during placement of drainfill shall be repaired before drainfill placement is continued.

The upper surface of drainfill constructed concurrently with adjacent zones of earthfill shall be maintained at a minimum elevation of 1 foot above the upper surface of adjacent earthfill.

Drainfill over and/or around pipe or drain tile shall be placed to avoid any displacement in line or grade of the pipe or tile.

Drainfill shall not be placed adjacent to structures until the concrete has attained the strength specified in section 9 of this specification. The strength shall be determined by compression testing of concrete

test cylinders cast and field cured at the project site in accordance with ASTM Method C 31 for determining when a structure may be placed into service.

When the required strength of the concrete is not specified as described above, placement of drainfill adjacent to concrete structures shall not be commenced until the following item intervals have elapsed following placement of the concrete:

| Structure type   | Time interval (days) |
|--|----------------------|
| Vertical or near-vertical wall with earth loading on one side only<br>(retaining walls and counterforts) | 14                   |
| Walls backfilled on both sides simultaneously  | 7                    |
| Conduits and galleries, cast-in-place<br>(with inside forms in place)                                    | 7                    |
| (inside forms removed)   | 14                   |
| Conduits, precast, cradled   | 2                    |
| Conduits, precast, bedded  | 1                    |
| Cantilever outlet bents backfilled on both sides simultaneously  | 3                    |

## 5. Control of moisture

The moisture content of drainfill material shall be controlled as specified in section 9 of this specification. When additional water is required, it shall be applied in a manner to avoid excessive wetting to adjacent earthfill. Except as specified in section 9 of this specification, control of moisture content will not be required.

## 6. Compaction

Drainfill shall be compacted according to the following requirements for the class of compaction specified:

**Class A compaction**—For drainfill materials with more than 70 percent passing the 3/4 inch sieve, each layer of drainfill shall be compacted to a minimum dry density of not less than the density specified in section 9 of this specification as determined by ASTM D 698. For drainfill materials with 70 percent or less passing the 3/4 inch sieve, each layer of drainfill shall be compacted to a relative density of not less than 70 percent as determined by ASTM D 4254.

**Class I compaction**—Each layer of drainfill shall be compacted by a minimum of two passes over the entire surface with a steel-drum vibrating roller weighing at least 5 tons and exerting a vertical vibrating force of not less than 20,000 pounds at a minimum frequency of 1,200 times per minute, or by an approved equivalent method.

**Class II compaction**—Each layer of drainfill shall be compacted by one of the following methods or by an approved equivalent method. (A pass is defined as at least one complete coverage of the roller wheel, tire, or drum over the entire surface for each layer.)

- a. A minimum of two passes over the entire surface with a pneumatic-tired roller exerting a minimum pressure of 75 pounds per square inch.
- b. A minimum of four passes over the entire surface with the track of a crawler-type tractor weighing at least 20 tons.
- c. Controlled movement of the hauling equipment so that the entire surface is traversed by not less than one tread track of the loaded hauling equipment.

**Class III compaction**—No compaction will be required beyond that resulting from the placing and spreading operations.

When compaction other than Class III compaction is specified, material placed in trenches or other locations inaccessible to heavy equipment shall be compacted by manually controlled pneumatic or vibrating tampers as specified in section 9 of this specification.

Heavy equipment shall not be operated within 2 feet of any structure. Vibrating rollers shall not be operated within 5 feet of any structure. Compaction by means of drop weights operating from cranes, hoists, or similar equipment will not be permitted.

## **7. Testing**

The contractor shall conduct such tests as necessary to verify that the drainfill material and the in-place drainfill meets the specification requirements.

The engineer shall be granted access to perform such tests as are required to verify that the drainfill materials and the drainfill in place meets the requirements of the specifications. These tests are not intended to provide the contractor with information needed to assure that the materials and workmanship meet the specification requirements. These verification tests will not relieve the contractor of the responsibility of performing required tests for that purpose.

## **8. Measurement and payment**

**Method 1**—For items of work for which specific unit prices are established in the contract, the volume of drainfill within the neat lines shown on the drawings are measured and computed to the nearest cubic yard. Where the engineer directs placement of drainfill outside the neat lines to replace unsuitable foundation material, the volume of such drainfill is included. The volume included is only to the extent that the unsuitable condition is not a result of the contractor's improper construction operation in the determination of the engineer.

Payment for drainfill is made at the contract unit price for each type of drainfill, complete in place. Except as otherwise specified in section 9 of this specification, such payment will constitute full compensation for all labor, equipment, material, and all other items necessary and incidental to the performance of the work.

**Method 2**—For items of work for which specific unit prices are established in the contract, the quantity of drainfill placed within the specified limits is computed to the nearest 0.1 ton by actual weight. Where the engineer directs placement of drainfill outside the neat lines to replace unsuitable foundation material, the weight of such drainfill is included. The weight included is only to the extent that the unsuitable condition is not a result of the contractor's improper construction operation in the determination of the engineer.

Payment for drainfill is made at the contract unit price for each type of drainfill, complete in place. Except as otherwise specified in section 9 of this specification, such payment will constitute full compensation for all labor, equipment, material, and all other items necessary and incidental to the performance of the work.

Compensation for any item of work described in the contract, but not included in the bid schedule is included in the payment for the item of work to which it is made subsidiary. Such items and the items to which they are made subsidiary are identified in section 9 of this specification.

## **9. Items of work and construction details**

**9. Items of work and construction details**

Items of work to be performed in conformance with this specification and the construction details are:

a. Subsidiary Item, Road Surfacing

- (1) This item consists of furnishing, processing, and placing all road surfacing materials associated with construction of the road raise and drivable dips as shown on the drawings.
- (2) In Section 2, Material 1 shall apply, gravel used to construct the gravel road surface shall be rock type 1 in accordance with Material Specification 523 with the following gradation:

Gravel Road Surfacing:

| <u>Size Opening</u> | <u>Percent Passing by Dry Weight</u> |
|---------------------|--------------------------------------|
| ¾ inch              | 100                                  |
| ½ inch              | 80-100                               |
| #4                  | 50 - 80                              |
| #40                 | 10 - 30                              |
| #200                | 5 - 15                               |

Drivable Dip Surfacing/Gravel Road Subgrade:

| <u>Size Opening</u> | <u>Percent Passing by Dry Weight</u> |
|---------------------|--------------------------------------|
| 1½ inch             | 100                                  |
| 1 inch              | 80 - 100                             |
| ½ inch              | 50 - 80                              |
| #4                  | 25 - 50                              |
| #40                 | 0 - 15                               |
| #200                | 0 - 5                                |

- (3) In Section 4, Placement, the maximum thickness before compaction shall not exceed four (4) inches.
- (4) In Section 9, Measurement and payment, no separate payment will be made for Road Surfacing. Compensation for Road Surfacing will be included in the payment for Bid Item 1, Earthfill.

# Construction Specification 61—Rock Riprap

## 1. Scope

The work shall consist of the construction of rock riprap revetments and blankets, including filter or bedding where specified.

## 2. Material

Rock riprap shall conform to the requirements of Material Specification 523, Rock for Riprap, or if so specified, shall be obtained from designated sources. It shall be free from dirt, clay, sand, rock fines, and other material not meeting the required gradation limits.

At least 30 days before rock is delivered from other than designated sources, the contractor shall designate in writing the source from which rock material will be obtained and provide information satisfactory to the contracting officer that the material meets contract requirements. The contractor shall provide the contracting officer's technical representative (COTR) free access to the source for the purpose of obtaining samples for testing. The size and grading of the rock shall be as specified in section 8.

Rock from approved sources shall be excavated, selected, and processed to meet the specified quality and grading requirements at the time the rock is installed.

Based on a specific gravity of 2.65 (typical of limestone and dolomite) and assuming the individual rock is shaped midway between a sphere and a cube, typical size/weight relationships are:

| Sieve size of rock | Approx. weight of rock | Weight of test pile |
|--------------------|------------------------|---------------------|
| 16 inches          | 300 pounds             | 6,000 pounds        |
| 11 inches          | 100 pounds             | 2,000 pounds        |
| 6 inches           | 15 pounds              | 300 pounds          |

When specified in Section 8 or when it is necessary to verify the gradation of the rock riprap, a particle size analysis shall be performed in accordance with ASTM D5519, Test Method A or B. The analysis shall be performed at the work site on a test pile of representative rock. The mass of the test pile shall be at least 20 times the mass of the largest rock in the pile.

The results of the test shall be compared to the gradation required for the project. Test pile results that do not meet the construction specifications shall be cause for the rock to be rejected. The test pile that meets contract requirements shall be left on the job site as a sample for visual comparison. The test pile shall be used as part of the last rock riprap to be placed.

**Filter or bedding aggregates** when required shall conform to Material Specification 521, Aggregates for Drainfill and Filters, unless otherwise specified. Geotextiles shall conform to Material Specification 592, Geotextile.

## 3. Subgrade preparation

The subgrade surface on which the rock riprap, filter, bedding, or geotextile is to be placed shall be cut or filled and graded to the lines and grades shown on the drawings. When fill to subgrade lines is required, it shall consist of approved material and shall conform to the requirements of the specified class of earthfill.

Rock riprap, filter, bedding, or geotextile shall not be placed until the foundation preparation is completed and the subgrade surface has been inspected and approved.

#### **4. Equipment-placed rock riprap**

The rock riprap shall be placed by equipment on the surface and to the depth specified. It shall be installed to the full course thickness in one operation and in such a manner as to avoid serious displacement of the underlying material. The rock for riprap shall be delivered and placed in a manner that ensures the riprap in place is reasonably homogeneous with the larger rocks uniformly distributed and firmly in contact one to another with the smaller rocks and spalls filling the voids between the larger rocks. Some hand placing may be required to provide a neat and uniform surface.

Rock riprap shall be placed in a manner to prevent damage to structures. Hand placing is required as necessary to prevent damage to any new and existing structures.

#### **5. Hand placed rock riprap**

The rock riprap shall be placed by hand on the surface and to the depth specified. It shall be securely bedded with the larger rocks firmly in contact one to another without bridging. Spaces between the larger rocks shall be filled with smaller rocks and spalls. Smaller rocks shall not be grouped as a substitute for larger rock. Flat slab rock shall be laid on its vertical edge except where it is laid like paving stone and the thickness of the rock equals the specified depth of the riprap course.

#### **6. Filter or bedding**

When the contract specifies filter, bedding, or geotextile beneath the rock riprap, the designated material shall be placed on the prepared subgrade surface as specified. Compaction of filter or bedding aggregate is not required, but the surface of such material shall be finished reasonably smooth and free of mounds, dips, or windrows.

#### **7. Measurement and payment**

**Method 1**—For items of work for which specific unit prices are established in the contract, the quantity of each type of rock riprap placed within the specified limits is computed to the nearest ton by actual weight. The volume of each type of filter or bedding aggregate is measured within the specified limits and computed to the nearest cubic yard by the method of average cross-sectional end areas. For each load of rock riprap placed as specified, the contractor shall furnish to the COTR a statement-of-delivery ticket showing the weight to the nearest 0.1 ton.

Payment is made at the contract unit price for each type of rock riprap, filter, or bedding. Such payment is considered full compensation for completion of the work.

**Method 2**—For items of work for which specific unit prices are established in the contract, the quantity of each type of rock riprap placed within the specified limits is computed to the nearest 0.1 ton by actual weight. The quantity of each type of filter or bedding aggregate delivered and placed within the specified limits is computed to the nearest 0.1 ton. For each load of rock riprap placed as specified, the contractor shall furnish to the engineer a statement-of-delivery ticket showing the weight to the nearest 0.1 ton. For each load of filter or bedding aggregate, the contractor shall furnish to the COTR a statement-of-delivery ticket showing the weight to the nearest 0.1 ton.

Payment is made at the contract unit price for each type of rock riprap, filter, or bedding. Such payment is considered full compensation for completion of the work.

**Method 3**—For items of work for which specific unit prices are established by the contract, the volume of each type of rock riprap and filter or bedding aggregate is measured within the specified limits and computed to the nearest cubic yard by the method of average cross-sectional end areas.

Payment is made at the contract unit price for each type of rock riprap, filter, or bedding. Such payment is considered full compensation for completion of the work.

**Method 4**—For items of work for which specific unit prices are established by the contract, the volume of each type of rock riprap, including filter and bedding aggregate, is measured within the specified limits and computed to the nearest cubic yard by the method of average cross-sectional end areas.

Payment is made at the contract unit price for each type of rock riprap, including filter and bedding. Such payment is considered full compensation for completion of the work.

**Method 5**—For items of work for which specific unit prices are established by the contract, the quantity of each type of rock riprap placed within the specified limits is computed to the nearest ton by actual weight. For each load of rock for riprap placed as specified, the contractor shall furnish to the COTR a statement-of-delivery ticket showing the weight to the nearest 0.1 ton.

Payment is made at the contract unit price for each type of rock riprap, including geotextile used for filter or bedding. Such payment is considered full compensation for completion of the work.

**Method 6**—For items of work for which specific unit prices are established by the contract, the volume of each type of rock riprap is measured within the specified limits and computed to the nearest cubic yard by the method of average cross-sectional end areas.

Payment is made at the contract unit price for each type of rock riprap, including geotextile used for filter or bedding. Such payment is considered full compensation for completion of the work.

**All methods**—The following provision applies to all methods of measurement and payment. Compensation for any item of work described in the contract, but not listed in the bid schedule, is included in the payment for the item of work to which it is made subsidiary. Such items and the items to which they are made subsidiary are identified in section 8.

No separate payment is made for testing the gradation of the test pile. Compensation for testing is included in the appropriate bid item for riprap.

## **8. Items of work and construction details**

**8. Items of work and construction details**

Items of work to be performed in conformance with this specification and the construction details are:

a. Subsidiary Item, 6-Inch Minus Rock

- (1) This item consists of furnishing and installing the rock riprap to construct the protection berm and drivable dip to the lines and grades as shown on the drawings.
- (2) In Section 2, Material, rock riprap used to construct the protection berm shall be rock type 1 in accordance with Material Specification 523, Rock for riprap, and shall be graded as follows:

| <u>Size Opening</u> | <u>Percent Passing by Dry Weight</u> |
|---------------------|--------------------------------------|
| 6 inch              | 100                                  |
| 4 inch              | 50 - 100                             |
| 3 inch              | 30 - 50                              |
| 1-1/2 inch          | 10 - 30                              |
| Less than 1 inch    | 0 - 10                               |

- (3) The source of rock riprap shall be from bedrock blasting and/or crushing operations. River rock shall not be used.
- (4) In Section 7, Measurement and payment, no separate payment will be made for 6-Inch Minus Rock. Compensation for 6-Inch Minus Rock will be included in the payment for Bid Item 1, Earthfill.

b. Subsidiary Item, 10-Inch Minus Loose Rock Riprap Facing

- (1) This item consists of furnishing and installing the rock riprap to construct the loose riprap facing to the lines and grades as shown on the drawings.
- (2) In Section 2, Material, rock riprap used to construct the loose riprap facing shall be rock type 1 in accordance with Material Specification 523, Rock for riprap, and shall be graded as follows:

| <u>Size Opening</u> | <u>Percent Passing by Dry Weight</u> |
|---------------------|--------------------------------------|
| 10 inch             | 100                                  |
| 6 inch              | 50 - 100                             |
| 4 inch              | 30 - 50                              |
| 2 inch              | 10 - 30                              |
| Less than 1 inch    | 0 - 10                               |

- (3) The source of rock riprap shall be from bedrock blasting and/or crushing operations. River rock shall not be used.



- (4) In Section 7, Measurement and payment, no separate payment will be made for 10-Inch Minus Loose Rock Riprap Facing. Compensation for 10-Inch Minus Loose Rock Riprap Facing will be included in the payment for Bid Item 1, Earthfill.

# Construction Specification 94—Contractor Quality Control

## 1. Scope

The work consists of developing, implementing, and maintaining a quality control system to ensure that the specified quality is achieved for all materials and work performed.

## 2. Equipment and materials

Equipment and material used for quality control shall be of the quality and condition required to meet the test specifications cited in the contract. Testing equipment shall be properly adjusted and calibrated at the start of operations and the calibration maintained at the frequency specified. Records of equipment calibration tests shall be available to the engineer at all times. Equipment shall be operated and maintained by qualified operators as prescribed in the manufacturer's operating instructions, the references specified, and as specified in section 10 of this specification. All equipment and materials used in performing quality control testing shall be as prescribed by the test standards referenced in the contract or in section 10.

All equipment and materials shall be handled and operated in a safe and proper manner and shall comply with all applicable regulations pertaining to their use, operation, handling, storage, and transportation.

## 3. Quality control system

**Method 1**—The contractor shall develop, implement, and maintain a system of quality control to provide the specified material testing and verification of material quality before use. The system activities shall include procedures to verify adequacy of completed work, initiate corrective action to be taken, and document the final results. The identification of the quality control personnel and their duties and authorities shall be submitted to the contracting officer in writing within 15 calendar days after notice of award.

**Method 2**—The contractor shall develop, implement, and maintain a system adequate to achieve the specified quality of all work performed, material incorporated, and equipment furnished before use. The system established shall be documented in a written plan developed by the contractor and approved by the contracting officer. The system activities shall include the material testing and inspection needed to verify the adequacy of completed work and procedures to be followed when corrective action is required. Daily records to substantiate the conduct of the system shall be maintained by the contractor. The quality control plan shall cover all aspects of quality control and shall address, as a minimum, all specified testing and inspection requirements. The plan provided shall be consistent with the planned performance in the contractor's approved construction schedule. The plan shall identify the contractor's onsite quality control manager and provide an organizational listing of all quality control personnel and their specific duties. The written plan shall be submitted to the contracting officer within 15 calendar days after notice of award. The contractor shall not proceed with any construction activity that requires inspection until the written plan is approved by the contracting officer.

**All methods**—The quality control system shall include, but not be limited to, a rigorous examination of construction material, processes, and operation, including testing of material and examination of manufacturer's certifications as required, to verify that work meets contract requirements and is performed in a competent manner.

#### **4. Quality control personnel**

**Method 1**—Quality control activities shall be accomplished by competent personnel. A competent person is: One who is experienced and capable of identifying, evaluating, and documenting that materials and processes being used will result in work that complies with the contract; and, who has authority to take prompt action to remove, replace, or correct such work or products not in compliance. Off-site testing laboratories shall be certified or inspected by a nationally recognized entity. The Contractor shall submit to the Contracting Officer, for approval, laboratory certification or inspection information. The Contractor shall submit to the Contracting Officer, for approval, the names, qualifications, authorities, certifications, and availability of the competent personnel who will perform the quality control activities.

**Method 2**—Quality control activities shall be accomplished by competent personnel who are separate and apart from line supervision and who report directly to management. A competent person is one who is experienced and capable of identifying, evaluating, and documenting that material and processes being used will result in work that complies with the contract, and who has authorization to take prompt action to remove, replace, or correct such work or products not in compliance. Offsite testing laboratories shall be certified or inspected by a nationally recognized entity. The Contractor shall submit to the Contracting Officer, for approval, laboratory certification or inspection information. The contractor shall submit to the contracting officer, for approval, the names, qualifications, authorities, certifications, and availability of the competent personnel who will perform the quality control activities.

#### **5. Post-award conference**

The contractor shall meet with the contracting officer before any work begins and discuss the contractor's quality control system. The contracting officer and the contractor shall develop a mutual understanding regarding the quality control system, including procedures for correcting quality control issues.

#### **6. Records**

The contractor's quality control records shall document both acceptable and deficient features of the work and corrective actions taken. All records shall be on forms approved by the contracting officer, be legible, and be dated and signed by the competent person creating the record.

Unless otherwise specified in section 10 of this specification, records shall include:

- a. Documentation of shop drawings including date submitted to and date approved by the contracting officer, results of examinations, any need for changes or modifications, manufacturer's recommendations and certifications, if any, and signature of the authorized examiner.
- b. Documentation of material delivered including quantity, storage location, and results of quality control examinations and tests.
- c. Type, number, date, time, and name of individual performing quality control activities.
- d. The material or item inspected and tested, the location and extent of such material or item, and a description of conditions observed and test results obtained during the quality control activity.
- e. The determination that the material or item met the contract provisions and documentation that the engineer was notified.
- f. For deficient work, the nature of the defects, specifications not met, corrective action taken, and results of quality control activities on the corrected material or item.

#### **7. Reporting results**

The results of contractor quality control inspections and tests shall be communicated to the engineer immediately upon completion of the inspection or test. Unless otherwise specified in section 10, the original plus one copy of all records, inspections, tests performed, and material testing reports shall be submitted to the engineer within one

working day of completion. The original plus one copy of documentation of material delivered shall be submitted to the engineer before the material is used.

## **8. Access**

The contracting officer and the engineer shall be given free access to all testing equipment, facilities, sites, and related records for the duration of the contract.

## **9. Payment**

**Method 1**—For items of work for which lump sum prices are established in the contract, payment is made as the work proceeds, after presentation by the contractor of invoices showing related costs and evidence of charges by suppliers, subcontractors, and others for furnishing supplies and work performed. If the total of such payments is less than the lump sum contract price for this item, the remaining balance is included in the final contract payment. Payment of the lump sum contract price constitutes full compensation for completion of the work.

Payment is not made under this item for the purchase cost of material and equipment having a residual value.

**Method 2**—For items of work for which lump sum prices are established in the contract, payment is prorated and paid in equal amounts on each monthly estimate. The number of months used for prorating shall be the number estimated to complete the work. The final month's prorate amount is made with the final payment. Payment as described above constitutes full compensation for completion of the work.

Payment is not made under this item for the purchase cost of material and equipment having a residual value.

**All methods**—Compensation for any item of work described in the contract, but not listed in the bid schedule, is included in the payment for the item of work to which it is made subsidiary. Such items and the items to which they are made subsidiary are identified in section 10.

## **10. Items of work and construction details**

## 10. Items of work and construction details

Items of work to be performed in conformance with this specification and the construction details are:

a. Subsidiary Item, Contractor Quality Control

- (1) This item consists of all contractor quality control required to install the project.
- (2) In Section 3, Quality control system, method 1 shall apply.
- (3) In Section 4, Quality control personnel, method 1 shall apply.
- (4) In Section 9, Payment, no separate payment will be made for Contractor Quality Control. Compensation for Contractor Quality Control will be included in the payment for Bid Item 1, Earthfill.

## Material Specification 523—Rock for Riprap

### 1. Scope

This specification covers the quality of rock to be used in the construction of rock riprap.

### 2. Quality

Individual rock fragments shall be dense, sound, and free from cracks, seams, and other defects conducive to accelerated weathering. Except as otherwise specified, the rock fragments shall be angular to subrounded. The least dimension of an individual rock fragment shall be not less than one-third the greatest dimension of the fragment. ASTM D 4992 provides guidance on selecting rock from a source.

Except as otherwise provided, the rock shall be tested and shall have the following properties:

#### Rock type 1

- **Bulk specific gravity (saturated surface-dry basis)**—Not less than 2.5 when tested in accordance with ASTM C 127 on samples prepared as described for soundness testing.
- **Absorption**—Not more than 2 percent when tested in accordance with ASTM C 127 on samples prepared as described for soundness testing.
- **Soundness**—The weight loss in 5 cycles shall not be more than 10 percent when sodium sulfate is used or more than 15 percent when magnesium sulfate is used.

#### Rock type 2

- **Bulk specific gravity (saturated surface-dry basis)**—Not less than 2.5 when tested in accordance with ASTM C 127 on samples prepared as described for soundness testing.
- **Absorption**—Not more than 2 percent when tested in accordance with ASTM C 127 on samples prepared as described for soundness testing.

- **Soundness**—The weight loss in 5 cycles shall be not more than 20 percent when sodium sulfate is used or more than 25 percent when magnesium sulfate is used.

#### Rock type 3

- **Bulk specific gravity (saturated surface-dry basis)**—Not less than 2.3 when tested in accordance with ASTM C 127 on samples prepared as described for soundness testing.
- **Absorption**—Not more than 4 percent when tested in accordance with ASTM C 127 on samples prepared as described for soundness testing.
- **Soundness**—The weight loss in 5 cycles shall be not more than 20 percent when sodium sulfate is used or more than 25 percent when magnesium sulfate is used.

### 3. Methods of soundness testing

**Rock cube soundness**—The sodium or magnesium sulfate soundness test for all rock types (1, 2, or 3) shall be performed on a test sample of  $5,000 \pm 300$  grams of rock fragments, reasonably uniform in size and cubical in shape, and weighing, after sampling, about 100 grams each. They shall be obtained from rock samples that are representative of the total rock mass, as noted in ASTM D 4992, and that have been sawed into slabs as described in ASTM D 5121. The samples shall further be reduced in size by sawing the slabs into cubical blocks. The thickness of the slabs and the size of the sawed fragments shall be determined by the size of the available test apparatus and as necessary to provide, after sawing, the approximate 100-gram samples. The cubes shall undergo five cycles of soundness testing in accordance with ASTM C 88.

Internal defects may cause some of the cubes to break during the sawing process or during the initial soaking period. Do not test any of the

**Material Specification 523** Rock for Riprap (continued)

cubes that break during this preparatory process. Such breakage, including an approximation of the percentage of cubes that break, shall be noted in the test report.

After the sample has been dried following completion of the final test cycle and washed to remove the sodium sulfate or magnesium sulfate, the loss of weight shall be determined by subtracting from the original weight of the sample the final weight of all fragments that have not broken into three or more fragments.

The test report shall show the percentage loss of the weight and the results of the qualitative examination.

**Rock slab soundness**—When specified, the rock shall also be tested in accordance with ASTM D 5240. Deterioration of more than 25 percent of the number of blocks shall be cause

for rejection of rock from this source. Rock shall also meet the requirements for average percent weight loss stated below.

- For projects located north of the Number 20 Freeze-Thaw Severity Index Isoline (fig. 523–1). Unless otherwise specified, the average percent weight loss for Rock Type 1 shall not exceed 20 percent when sodium sulfate is used or 25 percent when magnesium sulfate is used. For Rock Types 2 and 3, the average percent weight loss shall not exceed 25 percent for sodium sulfate soundness or 30 percent for magnesium sulfate soundness.
- For projects located south of the Number 20 Freeze-Thaw Severity Index Isoline, unless otherwise specified, the average percent weight loss for Rock Type 1 shall not exceed 30 percent when sodium sulfate is used or 38 percent when magnesium sulfate is used.

**Figure 523–1** Number 20 freeze-thaw severity index isoline (map approximates the map in ASTM D 5312)



**Material Specification 523** Rock for Riprap (continued)

For Rock Types 2 and 3, the average percent weight loss shall not exceed 38 percent for sodium sulfate soundness or 45 percent for magnesium sulfate soundness.

**4. Field durability inspection**

Rock that fails to meet the material requirements stated above (if specified), may be accepted only if similar rock from the same source has been demonstrated to be sound after 5 years or more of service under conditions of weather, wetting and drying, and erosive forces similar to those anticipated for the rock to be installed under this specification.

A rock source may be rejected if the rock from that source deteriorates in 3 to 5 years under similar use and exposure conditions expected for the rock to be installed under this specification, even though it meets the testing requirements stated above.

Deterioration is defined as the loss of more than one-quarter of the original rock volume, or severe cracking that would cause a block to split. Measurements of deterioration are taken from linear or surface area particle counts to determine the percentage of deteriorated blocks. Deterioration of more than 25 percent of the pieces shall be cause for rejection of rock from the source.

**5. Grading**

The rock shall conform to the specified grading limits after it has been placed within the matrix of the rock riprap. Grading tests shall be performed, as necessary, according to ASTM D 5519, Method A, B, or C, as applicable.